

## SF<sub>6</sub> Gas Insulated Ring Main Unit *Susol* RMU

A Compact switchgear solution for secondary power distribution networks.



**Susol**  
Super Solution

**Ring Main Unit**

**LS IS**

# Ring Main Unit

The best solution for Power Distribution



## Contents

- 4 Features
- 6 Configurations
- 8 Intelligent application
- 10 Main characteristics
- Detailed characteristics for each
- 15 Optional components
- 20 Operational sequence
- 21 Dimensions
- 22 Quality assurance



## Susol RMU

### A Compact Switchgear Solution for Secondary Distribution (Ring Main Unit Up to 24kV, SF<sub>6</sub> - Insulated)

**Susol RMU** is enable to install on medium voltage distribution network and mainly used for protection of transformers in compact substations. It is used for medium voltage distribution in compact substations, small buildings, residential housing complex, large shopping malls, airports, wind power, etc. comprising medium voltage networks.

The concept of **Susol RMU** is offering a choice of other switch-fuse combination or circuit breaker with relay for protection of the transformer.

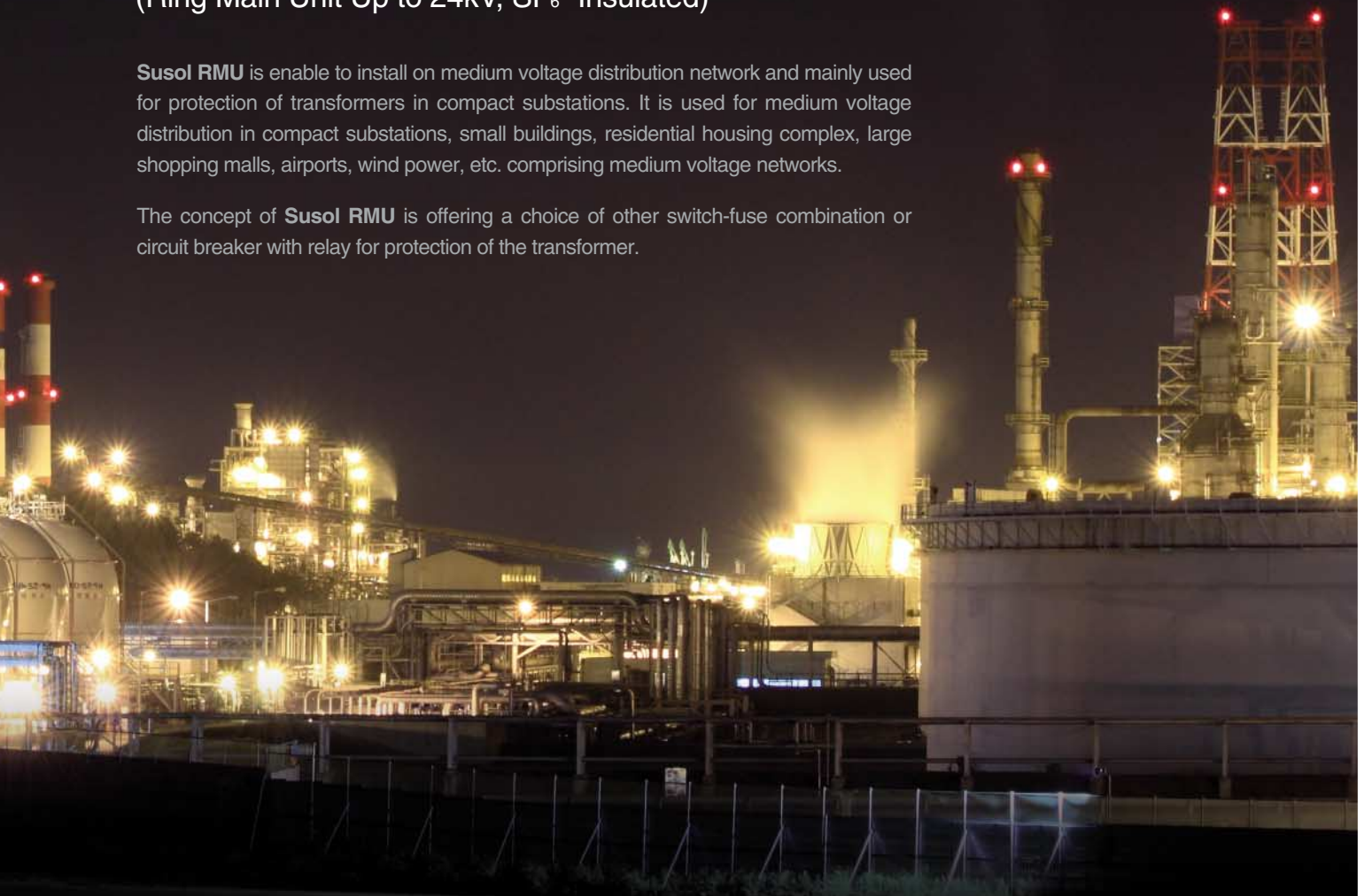





**Susol RMU**  is the solution to meet your medium voltage power distribution line needs.

**Susol RMU** is a compact ring main unit combining all MV functional units to enable to supply and protect transformers on the secondary distribution network.

**Susol RMU** can be supplied in various and different configurations suitable for most switching applications in 12/17.5/24 kV distribution networks.

## Technology

- Metal enclosed unit for Indoor installation and type tested.
- Insulated by SF<sub>6</sub> Gas.
- Maintenance free and easy installation.
- Independent of climate.
- ON-OFF-Earth, three position load break switch.
- Recyclable materials used.

## Safety

- Approachable and operable safely in the presence of power in the cables.
- Clear indication of operation status via mimic diagram on front panel.
- Fully automatic interlocking system.
  - Operation is only possible in case door is totally closed.
  - Fuse compartment is only accessible when Load break switch is earthed.
  - Voltage detector to check whether cables are lined or not.
- Rupture disk is designed to protect devices in case of emergency like gas expansion.
- Internal arc withstand is tested for the operator safety in case of accident current occur. (21kA/1s, without SF<sub>6</sub> Gas)

## Durability and usefulness

- Metal enclosed tank is hermetically sealed, it means this is independent of environmental effects such as dirt, small insects, moisture and so on.
- Load break switch operating is possible in the front of Ring Main Unit.
- All switching operations can be made safely to personnel because of interlocking system that operates automatically according to the switch position by the operator.
- No requirement of recharging SF<sub>6</sub> gas until its service life.
- Remote operation available in case of using motor operating mechanism and FRTU.
- HRC power fuse will trip the mechanism automatically by a fuse striker pin connected to mechanism in the event of fault happening.

## Saving cost

- No maintenance is required other than replacement of HRC Power Fuse after installation.
- Compact design that requires minimum space to install and operate locally is main advantage especially where the space is limited.
- No additional costs for replacement because of long service life.
- Materials can be recycled after the end of its service life.

## CB type (LCL) & Fuse type (LFL) RMU



LCL type

LFL type





## CB type RMU (LCL)

Susol RMU offers a choice of solutions to make 2,3 or 4 directional connections with line protection by 630A CB, with network switching by switch-disconnectors with integrated power supply telecontrol device

- **L : LBS (Load Break Switch)**

Three position Load Break Switch below 630A with disconnecting and earthing switch

- **C : VCB (Vacuum Circuit Breaker)**

200A vacuum circuit-breaker for transformer protection 400/630A circuit-breaker for feeder protection

- **Cable bushing horizontal in front**

- ① Ring S/W Earth operation
- ② Circuit Breaker operation
- ③ Ring S/W operation
- ④ Pressure gauge
- ⑤ Earth S/W operation
- ⑥ Name plate
- ⑦ Voltage Indicator
- ⑧ Disconnecter S/W operation
- ⑨ Cable compartment

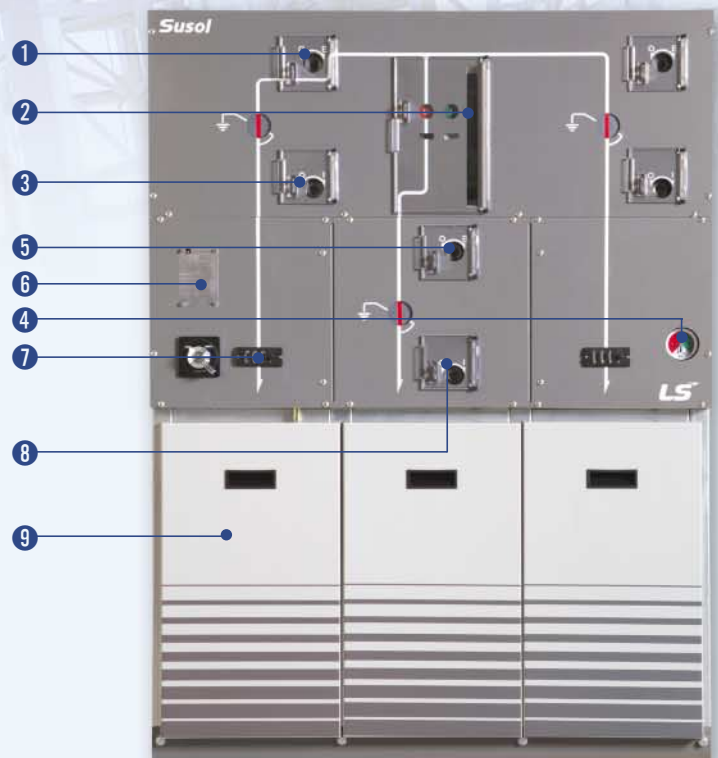

## Configurations

### • Information of model name

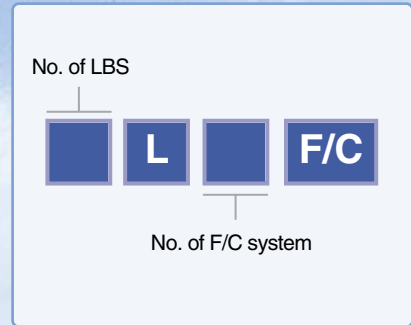
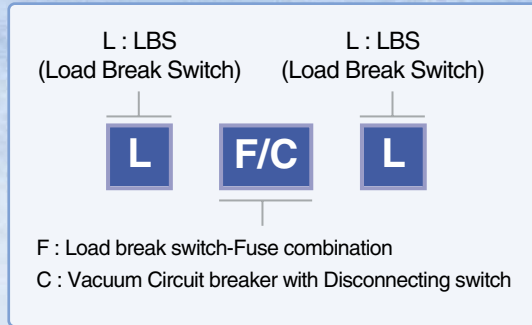

### • Diagram, standard types

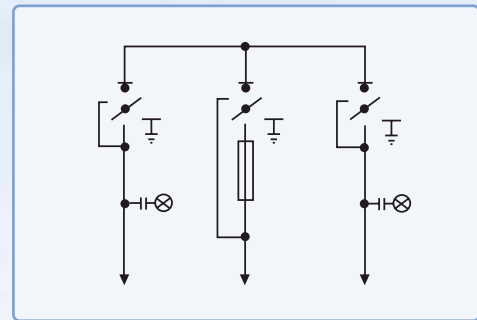
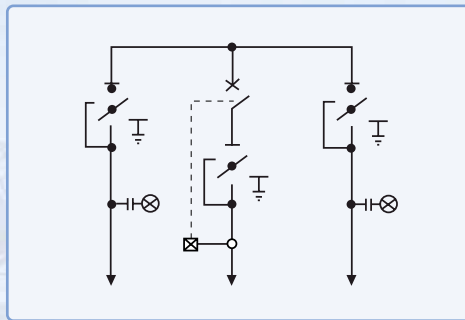

## Fuse type RMU (LFL)

LFL-model of Susol RMU offers the solution of transformer protection by fuses

- **L : LBS (Load Break Switch)**  
Three position Load Break Switch below 630A with disconnecting and earthing switch
- **F : Switch Fuse (Load Break Switch-Fuse combination)**  
200A switch-fuse combination for transformer protection
- **Cable bushing horizontal in front**

- ① Ring S/W Earth operation
- ② T-off operation
- ③ Ring S/W operation
- ④ Pressure gauge
- ⑤ Voltage Indicator
- ⑥ Cable compartment
- ⑦ Fuse compartment
- ⑧ Name plate

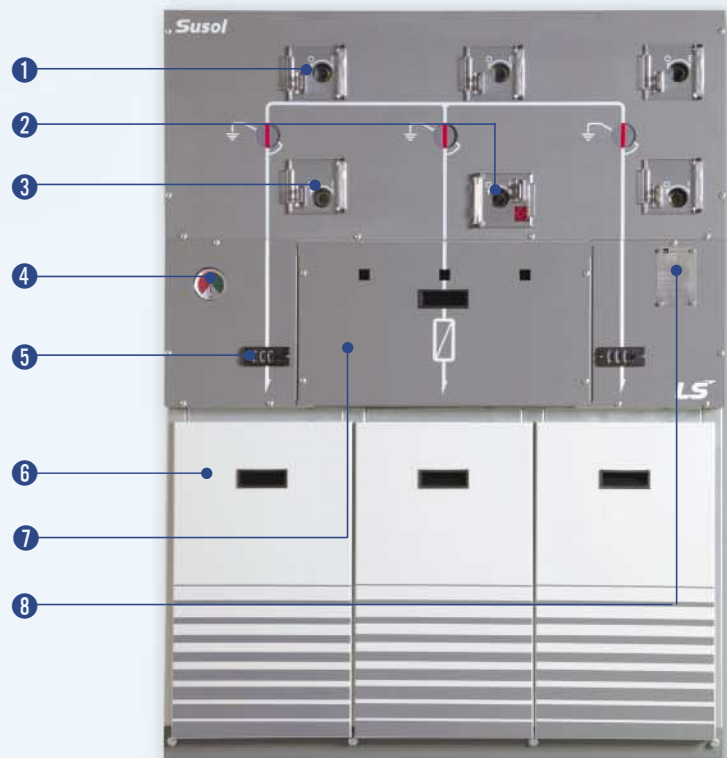



## Intelligent application

Equipped with RTU (Remote Terminal Unit), the Susol RMU switchgear can implement intelligent application. Connecting all Susol RMU with communication network, it enables to monitor and control the switchgear remotely.



- RTU (Remote Terminal Unit)



The Remote Terminal Unit(RTU) collects data from field instruments & sensors and transmits the information to the Supervisory Control and Data Acquisition System (SCADA) installed in a central control room through communication systems and lines, and receives control commands from the telemeter telecontrol system to conduct online controls in real time.



## Network remote control for DAS/SCADA

Equipped with RTU (remote termination unit), the Susol RMU switchgear can implement intelligent application. Connecting all the IRMUs by a communication network, it enable to monitor and control the switchgear remotely, locate and isolate fault automatically as well as the system recovery. This will dramatically reduce the affected area and duration of blackout, and realize the high reliability and excellent power quality.

- System configuration

Susol RMU equipped with RTU provides all the functions needed to operate the MV network in real time

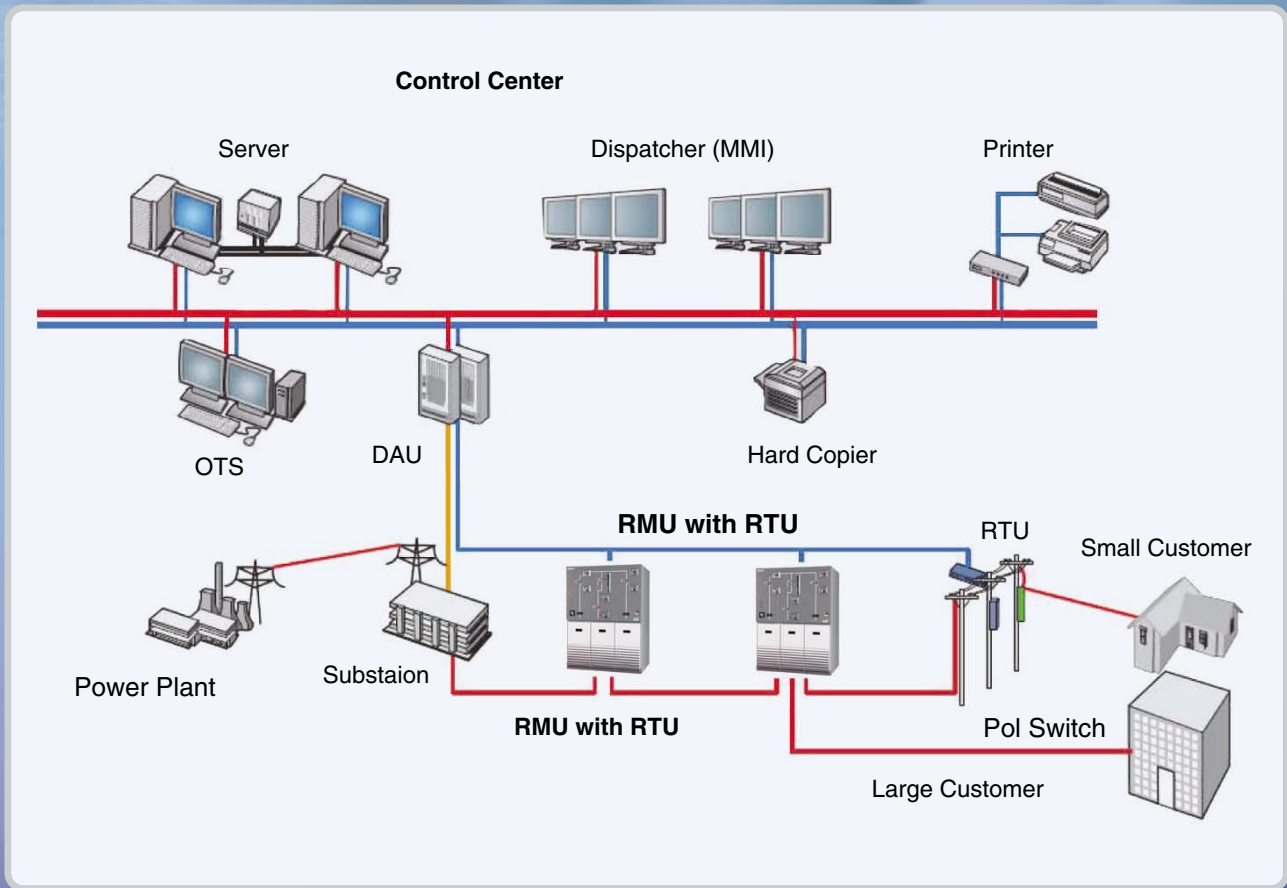

# Main characteristics

Susol



LCL type



LFL type

## Rating

Rated voltage	kV	12	17.5	24
Rated frequency	Hz	50/60	50/60	50/60
Rated power frequency withstand voltage	kV	28	38	50
Rated lightning impulse withstand voltage	kV	75	95	125
Rated current main busbars	A	630	630	630
Rated short-time withstand current (3s)	kA	21	21	21
Rated short-circuit making current	kA	54.6	54.6	54.6
Internal arc fault current (1s, AFAL)	kA	21	21	21
Rated SF <sub>6</sub> gas pressure	Psi.G	5	5	5

## Standards

Susol RMU meets international standards such as following

Standard	Description
IEC 62271-1	High-voltage switchgear and controlgear Part 1: Common specifications
IEC 62271-100	High-voltage switchgear and controlgear Part 100: Alternating-current circuit-breakers
IEC 62271-102	High-voltage switchgear and controlgear Part 102: Alternating current disconnectors and earthing switches
IEC 62271-103	High-voltage switchgear and controlgear Part 103: Switches for rated voltages above 1 kV up to and including 52 kV
IEC 62271-105	High-voltage switchgear and controlgear Part 105: Alternating current switch-fuse combinations
IEC 62271-200	High-voltage switchgear and controlgear Part 200: AC metal-enclosed switchgear and controlgear for rated voltages above 1 kV and up to and including 52 kV

## Environment conditions

Conditions	Description
Temperatures	- The cubicles must be stored and installed in a dry area free from dust and with limited temperature variations. - For stocking : from -40 °C to +60 °C - For working : from -25 °C to +40 °C - Other temperature, consult us.
Altitude	- Altitude for installation above sea level : under 1,000 m
Humidity	- Relative humidity : max. 95 %

## Additional information

Conditions	Description
Global options	- Manometer - VIS(Voltage Indication Systems) - All cable covers with interlock system - Fuse cover with interlock system
User options	- Internal arc exhausting box for 21kA/1s - Remote operating system for Load break switch - Remote operating system for fuse combination switch - Remote operating system for circuit breaker - OCR(Over Current Relay) operating Circuit breaker - Padlock system (key locking devices)
Protection index	- IP3X on front face, IP67 for SF <sub>6</sub> tank

## Types and diagrams

Dimension (W×H×D), mm

### 1. standard type

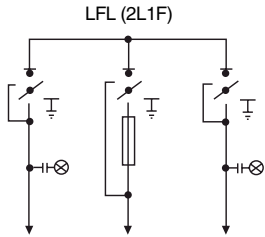
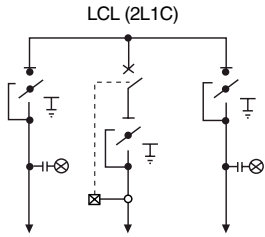
<p style="text-align: center;">LFL (2L1F)</p>  <p style="text-align: center;">1030 × 1400 × 752</p>	<p style="text-align: center;">LCL (2L1C)</p>  <p style="text-align: center;">1030 × 1400 × 752</p>
--	--

### 2. Load break switch combinations

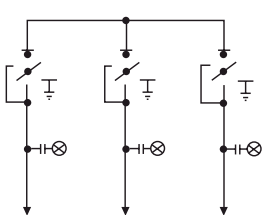
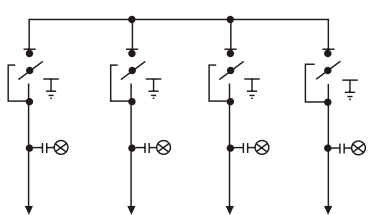
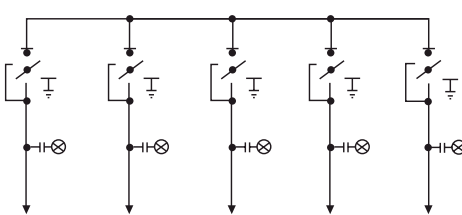
<p style="text-align: center;">LLL (3L)</p>  <p style="text-align: center;">1030 × 1400 × 752</p>	<p style="text-align: center;">LLLL (4L)</p>  <p style="text-align: center;">1390 × 1400 × 752</p>	<p style="text-align: center;">LLLLL (5L)</p>  <p style="text-align: center;">1720 × 1400 × 752</p>
---	--	--

### 3. Transformer protection by circuit breakers

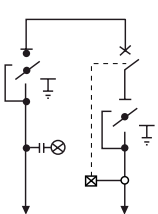
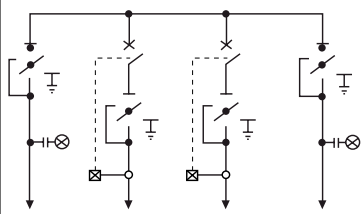
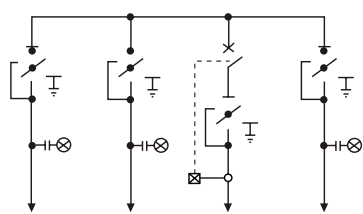
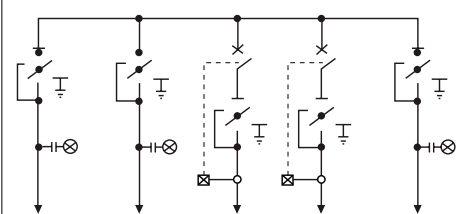
<p style="text-align: center;">LC (1L1C)</p>  <p style="text-align: center;">755 × 1400 × 752</p>	<p style="text-align: center;">LCCL (2L2C)</p>  <p style="text-align: center;">1450 × 1400 × 752</p>	<p style="text-align: center;">LLCL (3L1C)</p>  <p style="text-align: center;">1390 × 1400 × 752</p>	<p style="text-align: center;">LLCCL (3L2C)</p>  <p style="text-align: center;">1780 × 1400 × 752</p>
---	---	--	--

### 4. Transformer protection by fuses

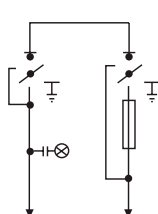
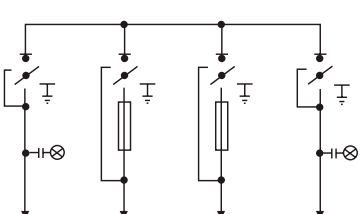
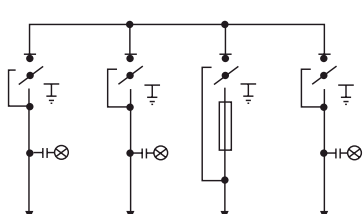
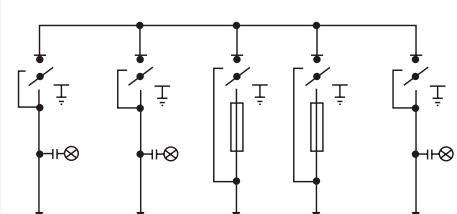
<p style="text-align: center;">LF (1L1F)</p>  <p style="text-align: center;">755 × 1400 × 752</p>	<p style="text-align: center;">LFFL (2L2F)</p>  <p style="text-align: center;">1500 × 1400 × 752</p>	<p style="text-align: center;">LLFL (3L1F)</p>  <p style="text-align: center;">1360 × 1400 × 752</p>	<p style="text-align: center;">LLFFL (3L2F)</p>  <p style="text-align: center;">1830 × 1400 × 752</p>
---	---	--	--



# Load Break Switch

Susol

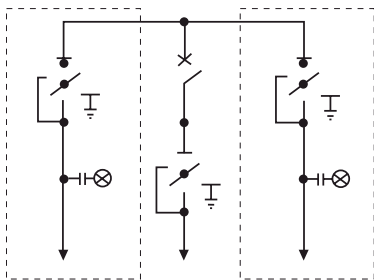
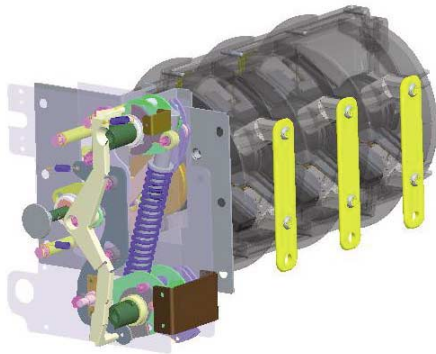

## Rating

<b>Rated voltage</b>	<b>kV</b>	<b>12</b>	<b>17.5</b>	<b>24</b>
Rated frequency	Hz	50/60	50/60	50/60
Rated power frequency withstand voltage	kV	28	38	50
Rated lightning impulse withstand voltage	kV	75	95	125
Rated current	A	630	630	630
Rated short-time withstand current (3s)	kA	21	21	21
Rated short-circuit making current	kA	54.6	54.6	54.6
Electrical endurance class		E3	E3	E3
Mechanical endurance class		M1	M1	M1
<b>Earthing switch</b>				
Rated short-time withstand current (3s)	kA	21	21	21
Rated short-circuit making current	kA	54.6	54.6	54.6
Electrical endurance class		E1	E1	E1
Mechanical endurance class		M1	M1	M1

\* M1: 1,000 Mechanical Operations

## Standard features

- Three position load break switch with disconnect and earthing switch
- Operating mechanism with two separate shaft for load and earthing function
- Switch position indication for LBS and ES
- Cable bushing horizontal in front with integrated capacitor for voltage indication

## Optional features

- Motor operation for load break switch
- Auxiliary switches
  - Load break switch position
  - Earthing switch position
- Voltage indicating system
- Short circuit and earth fault indicator

## Operation of 3-Position Load Break Switch

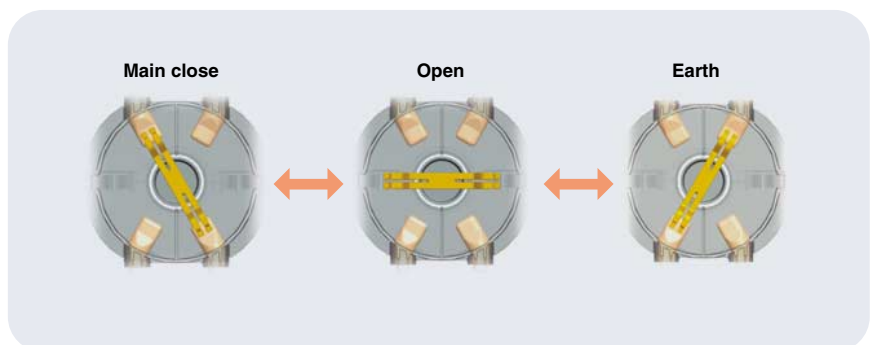

# Circuit Breaker

Susol

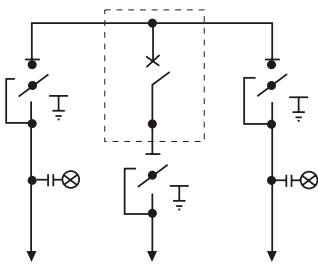
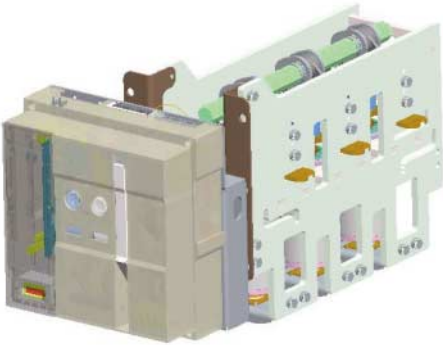

## Rating

Rated voltage	kV	12	17.5	24
Rated frequency	Hz	50/60	50/60	50/60
Rated power frequency withstand voltage	kV	28	38	50
Rated lightning impulse withstand voltage	kV	75	95	125
Rated current	A	200/630	200/630	200/630
Rated short-time withstand current (3s)	kA	21	21	21
Rated short-circuit making current	kA	54.6	54.6	54.6
Electrical endurance class		E2	E2	E2
Mechanical endurance class		M1	M1	M1
<b>Disconnecter and Earthing switch</b>				
Rated current	A	630	630	630
Rated short-time withstand current (3s)	kA	21	21	21
Rated short-circuit making current	kA	54.6	54.6	54.6
Electrical endurance class		E1	E1	E1
Mechanical endurance class		M1	M1	M1

\* M1: 2,000 Mechanical Operations

## Standard features

- 200 A vacuum circuit-breaker for transformer protection or 630 A vacuum circuit-breaker for feeder protection
- Three position disconnecting and earthing switch
- Switch position indication for CB and DS/ES
- Cable bushing horizontal in front
- Interlocking between CB and DS/ES

## Optional features

- Motor operation for circuit breaker
- Auxiliary switches
  - CB position
  - Disconnecter position
  - Earthing switch position
- Voltage indicating system
- Trip coil and close coil

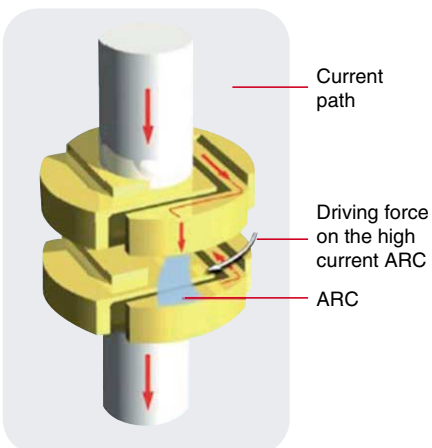

## Vacuum interrupter

In the closed position, normal current flows through the interrupter. When a fault occurs and interruption is required, the contacts are quickly separated. The arc drawn between the surfaces of contact is rapidly moved around the slotted contact surface by self induced magnetic effects, preventing gross contact erosion and the formation of hot spot on the surface. The arc burns in an ionized metal vapor, which condenses on the surrounding metal shield. At current zero the arc extinguishes and vapor production ceases. The metal vapor plasma is very rapidly dispersed, cooled, recombined, and deionized, and the metal vapor products are quickly condensed so that the contacts withstand the transient recovery voltage.

# Switch-fuse combination

Susol

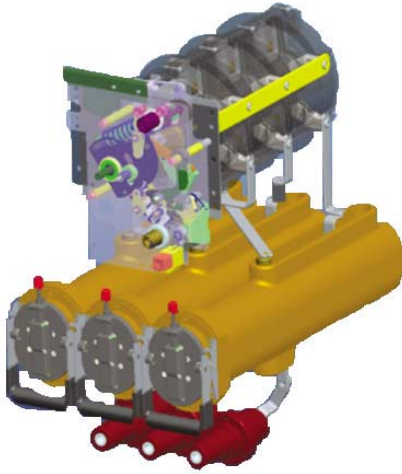

## Rating

<b>Rated voltage</b>	<b>kV</b>	<b>12</b>	<b>17.5</b>	<b>24</b>
Rated frequency	Hz	50/60	50/60	50/60
Rated power frequency withstand voltage	kV	28	38	50
Rated lightning impulse withstand voltage	kV	75	95	125
Rated current	A	200	200	200
Electrical endurance class		E1	E1	E1
Mechanical endurance class		M1	M1	M1
<b>Earthing switch</b>				
Rated short-time withstand current (1s)	kA	5	5	5
Rated short-circuit making current	kA	13	13	13
Electrical endurance class		E1	E1	E1
Mechanical endurance class		M1	M1	M1

\* M1: 1,000 Mechanical Operations

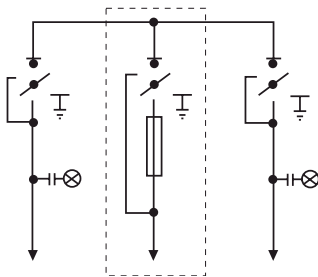

## Standard features

- Three position switch-fuse combination with earthing switch
- Switch position indication for switch-fuse combination and earth switch
- Cable bushing horizontal in front
- Fuse holder for DIN type fuse-links
- Fuse-link rating
  - 12/17.5kV: max. 100 A, LSIS DIN type fuse-link
  - 24kV: max. 75 A, LSIS DIN type fuse-link
- Automatically tripped to protect from fault current when a fuse is blown

## Optional features

- Motor operation for switch-fuse combination
- Auxiliary switches
  - LBS position
  - Earthing switch position
  - Fuse blown status
- Voltage indicating system
- Trip coil

# Cable compartment

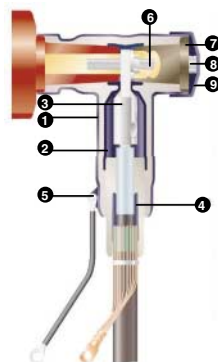
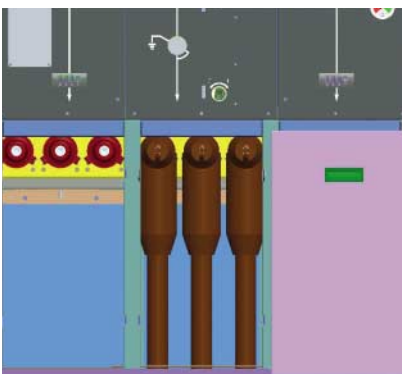

1. Screened body
2. Inner screen
3. Compressing lug
4. Stress cone adapter
5. Earthing eye and lead
6. Threaded pin
7. Rear plug with test point
8. Test point
9. Conductive end cap



# Optional components

Susol

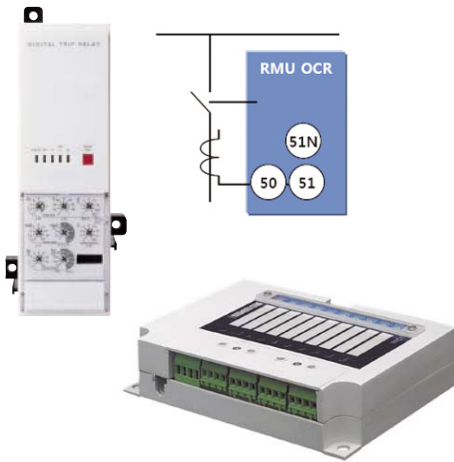

## OCR (Current Relay) : CT powered protection relay

This relay is self-powered relay by the CT in Susol RMU and can be set with definite time and inverse time characteristics for short circuit, overload and earth fault current. Parameter setting can be done in different user-friendly ways, computer controlled or with HEX switches on the front. The relay is also provided with a digital memory for the storage of the most recent tripping values. This relay has proven to be a reliable and widely accepted method of protection in worldwide distribution networks.

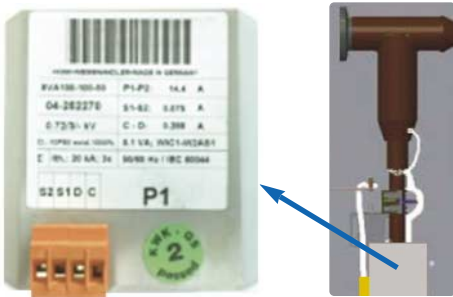

## CT(Current transformer )

Max. system voltage	kV	0.6
Primary current	A	7.2~230.4
Secondary current	A	0.075
Rated burden	VA	0.1
Accuracy class		10P80
Short time-current	KA/1s	20
Rated frequency	Hz	50/60



## Voltage indicator lamps (Voltage Detector)

It is a device to check the presence or absence of voltage in the cables. It is conforming to IEC standard 61958. Push button type LED voltage indicator is provided and lamp power is supplied by bushing type capacitive dividers.

# Optional components

Susol



## Power Fuse

### Features

1. The LS HRC Power Fuses belong to the PRIME MEC series. It interrupts high currents before the peak value and therefore cuts down the required withstand capacity of the associated equipment on the electric system.
2. Though small in size, it has a high breaking capacity and its enclosed type is suitable for use inside of the panel board.
3. PRIME-MEC fuses are equipped with striker pins for trip indicators as well as for inflicting impulse to trip link of related load break switches.

### Selection of fuses: According to IEC 60787(24kV)

Transformer rating capacity (kVA)	Power Fuse rated current (A)
36 ~ 75	5
75 ~ 157	10
172 ~ 358	20
258 ~ 538	30
464 ~ 965	40
598 ~ 1246	50
745 ~ 1554	63
1000 ~ 1983	75

Note) Please ask fuse maker for optimum selection of fuses.

### Power fuse characteristic curve

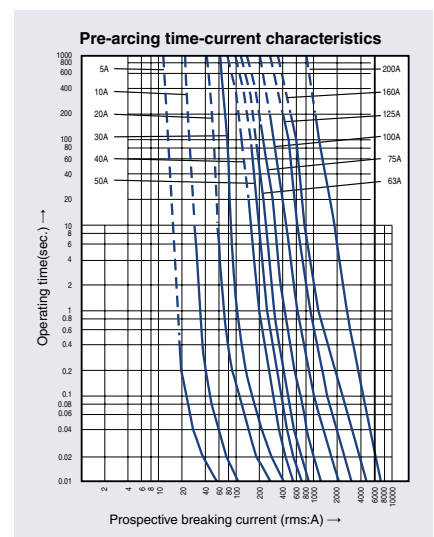
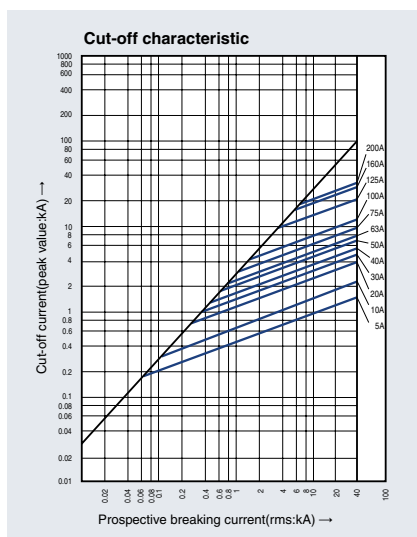

# Optional components

Susol

## Optional components for CB mechanism

### CB Mechanism

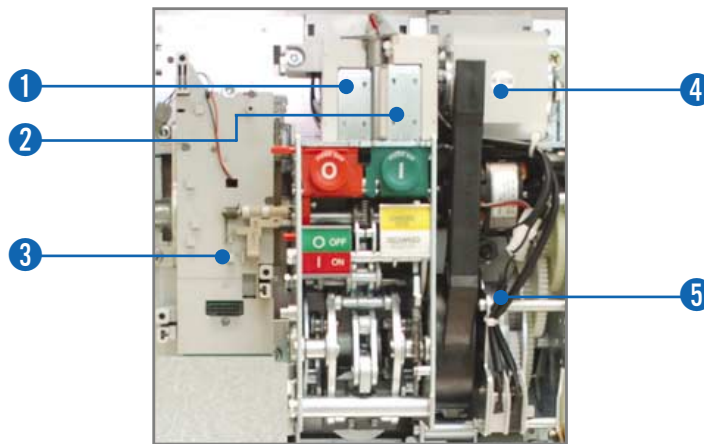

#### 1 SHT coil for CB

SHT is a control device which trips a circuit breaker from remote place, when applying voltage continuously or instantaneously over 200ms to coil terminals



#### 2 Closing coil for CB

It is a control device which closes a circuit breaker, when the voltage is applied continuously or instantaneously over 200ms to the coil terminals



#### 3 MTD (Magnetic Tripping Device)

It is a control device which trips a circuit breaker from the OCR, when the short circuit current or overload current occurred

\*Tripping time could be set by the OCR t-settings



#### 4 Auxiliary switch for CB

It is a contact used to monitor ON/OFF position of circuit breaker from remote place

\*Standard ON charge 5a5b/ Standard OFF charge 5a5b



#### 5 Geared motor for CB

Charge the closing spring of a circuit breaker by the external power source. Without the external power source, charge manually.

\*Operating voltage range → 85%~110% Vn



# Optional components

Susol

## Optional components for LBS/F-LBS mechanism

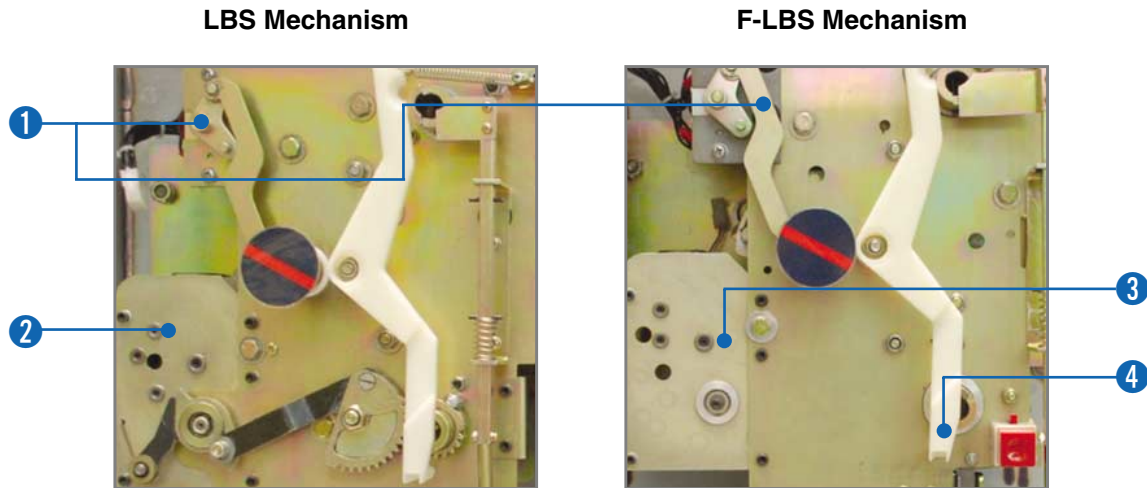

### 1 Auxiliary switch for LBS/F-LBS

It is a contact used to monitor ON/OFF position of Load break switch/fuse combination switch from remote place

\*Standard ON/OFF/EARTH for each position



### 2 Geared motor for LBS mech

Charge the closing and opening spring of a load break switch by the external power source. Without the external power source, charge source. manually.

\*Operating voltage range → 85%~110% Vn



### 3 Geared motor for F-LBS mech

Charge the closing spring of a fuse combination switch by the external power source. Without the external power source charge manually source. source, manually.

\*Operating voltage range → 85%~110% Vn



### 4 SHT coil for F-LBS mech

SHT is a control device which trips a fuse combination switch from remote place when applying voltage continuously or instantaneously place, over 200ms to coil terminals

### CB-Trip alarm contact

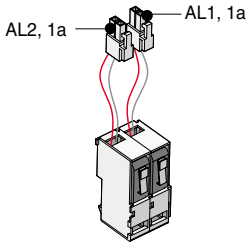

- When a circuit breaker is tripped by OCR which operates against the fault current(Over Current Relay), Trip Alarm switch provides the information regarding the trip of circuit breaker by sending the electrical signal from the mechanical indicator on main cover of main circuit breaker or internal auxiliary switch. (Installed at the inside of circuit breaker)
- When a circuit breaker is tripped by fault current, a mechanical trip indicator(MRB, Manual Reset Button) pops out from the main cover and the switch(AL) which sends control signal electrically is conducted to output the information occurred from fault circuit breaker
- MRB and AL can be operated only when tripped by OCR, but doesn't be operated by Off button and OFF operation of trip coil.
- To re-close a circuit breaker after a trip, press MRB to reset it for closing.
- 2pcs of electrical trip switch(AL1, AL2, 1a) are provided(Option)
- Trip alarm contact and MRB(Manual reset button) need to be purchased together

### MRB (Manual Reset Button)



- It is a function which resets a circuit breaker manually when a circuit breaker is tripped by OCR.
- When a circuit breaker tripped by fault current, a mechanical trip indicator(MRB,Manual Reset Button)pops out from the main cover and the switch(SDE)which sends control signal electrically is conducted to output the information occurred from fault circuit breaker.
- MRB can be operated only by OCR but not by OFF operation of circuit breaker, To re-close a circuit breaker after a trip, press MRB to reset it for closing.

### EFI (Earth fault indicator)



EFI can be installed at RMU frame or anywhere customer wants.

- Single Phase AC supply split core type sensor
- Automatic resetting function on AC 220~230V3Ph
- 3Phase

# Operational sequence

Susol

## Operational sequence for CB

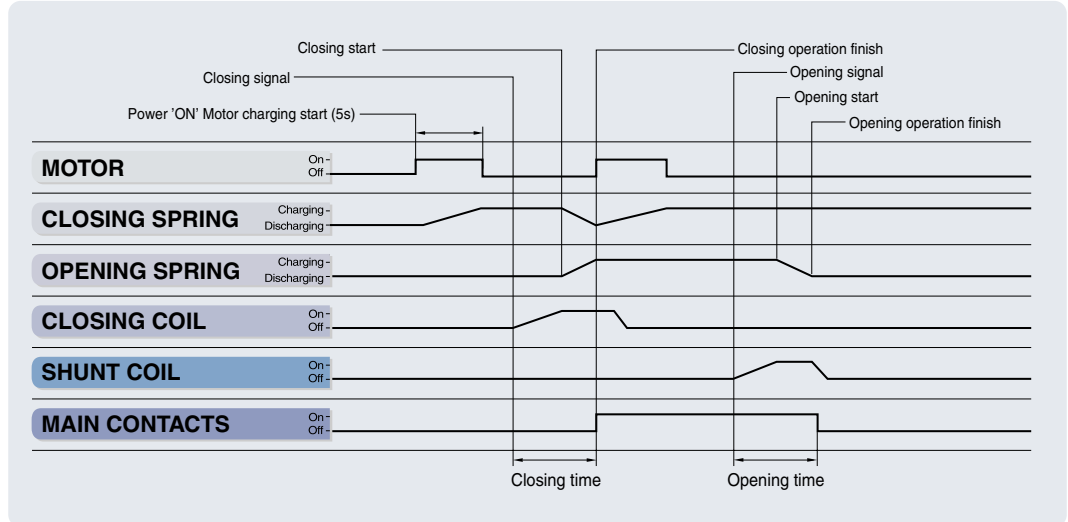

## Operational sequence for LBS

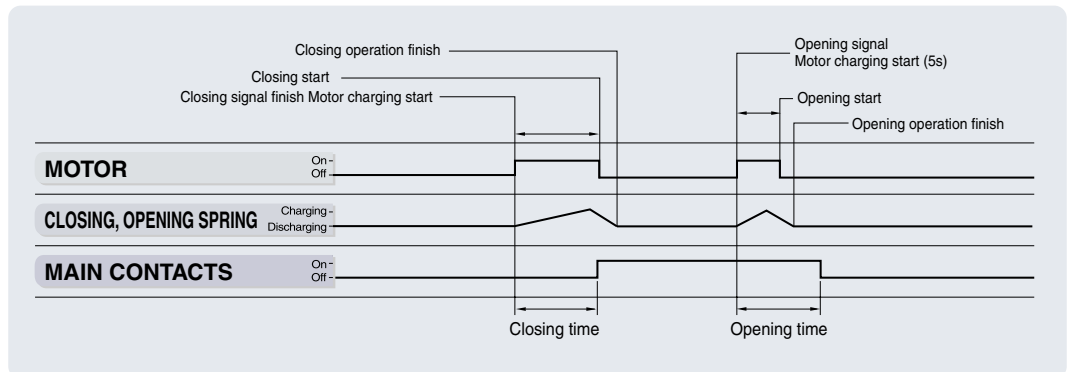

## Operational sequence for F-LBS

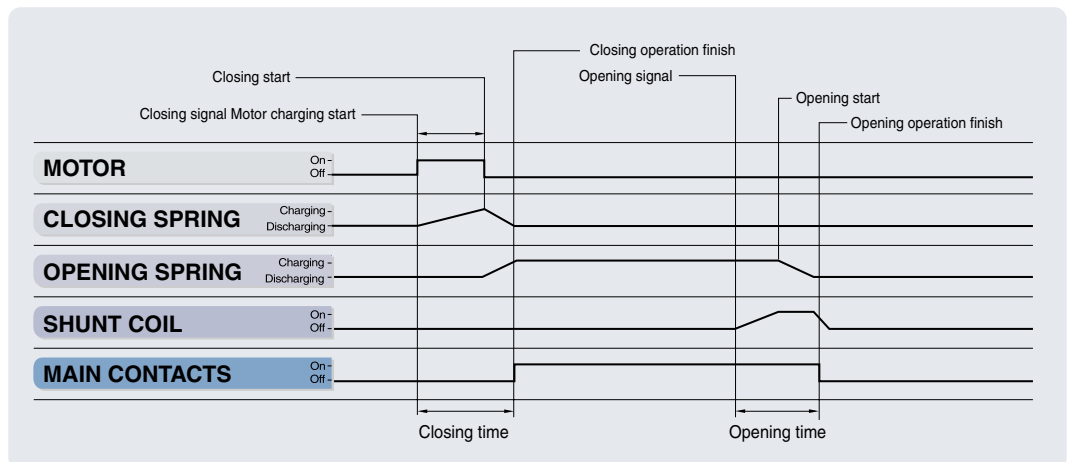

# Dimensions

Susol

## LCL (2L1C)

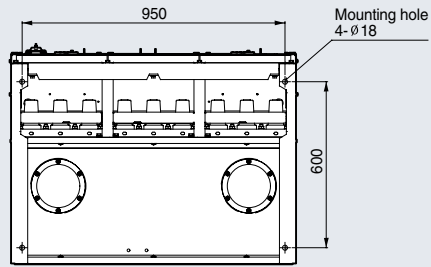

A-view

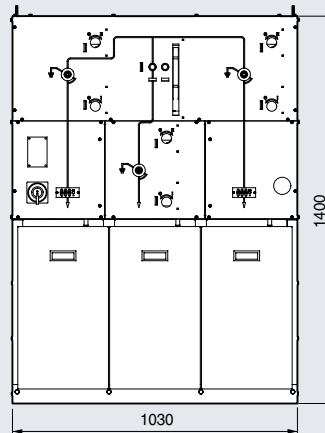

A

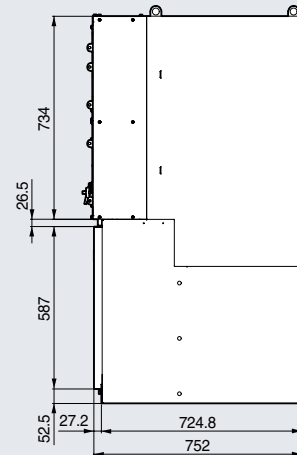

## LFL (2L1F)

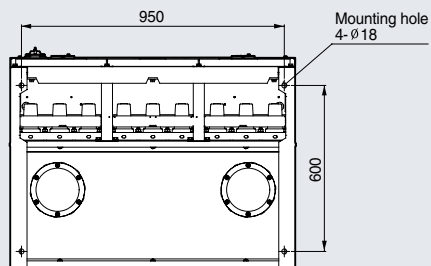

A-view

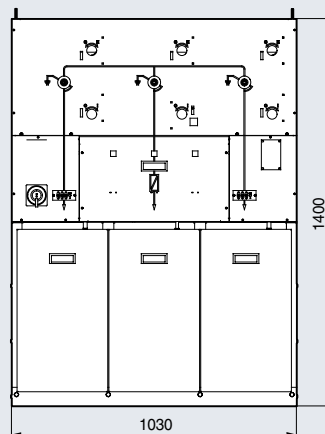

A

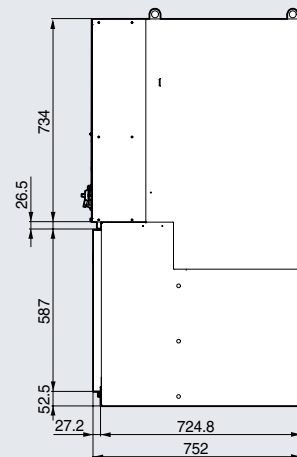



# Quality assurance

Susol

## Certified quality

: STL(The Short-Circuit Testing Liaison, KERI), ISO 9001, ISO 14001

LSIS has integrated a functional organization into each of its units, the main purpose of which is to check quality and ensure the adherence to standards.



## Routine quality check

While producing Susol RMU, various routine tests are taken for product capacity. Tested items are as shown follows.

- Filling pressure check
- Tightness check
- Manual and motor operation check
- Dielectric check
- Contact resistance check

# Ordering Information

LFL	B	24	62	12	D				
Type	Operation	Code	Rated Voltage	Code	Rated Current (Main/T-OFF)	Code	BIL	Code	DIN Type Bushing : D
LFL	Manual	B	24kV	12	630/630A	66	125kV BIL	12	
LCL	AC 110V	A1	17.5kV	17	630/400A	64	95kV BIL	09	
LLL	AC 220V	A2	12kV	24	630/200A	62	75kV BIL	07	
LLLL	DC 110V	D1			630/-A	60			
LCCL	DC 220V	D2							
LFFL									
LLCL									
LLFL									



## Green Innovators of Innovation



### Safety Instructions

- For your safety, please read user's manual thoroughly before operating.
- Contact the nearest authorized service facility for examination, repair, or adjustment.
- Please contact a qualified service technician when you need maintenance. Do not disassemble or repair by yourself!
- Any maintenance and inspection shall be performed by the personnel having expertise concerned.

## LSIS Co., Ltd.

© 2012. 10 LSIS Co.,Ltd. All rights reserved.

[www.lsis.biz](http://www.lsis.biz)

### ■ HEAD OFFICE

LS-ro 127 (Hogye-dong) dongan-gu Anyang-si  
Gyeonggi-do Korea  
Tel. (82-2)2034-4887, 4873, 4918, 4148  
Fax. (82-2)2034-4648

### ■ CHEONG-JU PLANT

Cheong-Ju Plant #1, Song Jung Dong, Hung Duk Ku,  
Cheong Ju, 361-720, Korea

### ■ Global Network

- **LSIS (Middle East) FZE >> Dubai, U.A.E.**  
Address: LOB 19 JAFZA VIEW TOWER Room 205, Jebel Ali Freezone P.O. Box 114216, Dubai, United Arab Emirates  
Tel: 971-4-886 5360 Fax: 971-4-886-5361 e-mail: dhleef@lsis.biz
- **Dalian LSIS Co., Ltd. >> Dalian, China**  
Address: No.15, Liaohexi 3-Road, Economic and Technical Development zone, Dalian 116600, China  
Tel: 86-411-8273-7777 Fax: 86-411-8730-7560 e-mail: tangyh@lsis.com.cn
- **LSIS (Wuxi) Co., Ltd. >> Wuxi, China**  
Address: 102-A, National High & New Tech Industrial Development Area, Wuxi, Jiangsu, 214028, P.R.China  
Tel: 86-510-8534-6666 Fax: 86-510-522-4078 e-mail: luw@lsis.com.cn
- **LSIS-VINA Co., Ltd. >> Hanoi, Vietnam**  
Address: Nguyen Khe - Dong Anh - Ha Noi - Viet Nam  
Tel: 84-4-882-0222 Fax: 84-4-882-0220 e-mail: sjbaik@lsis.biz
- **LSIS-VINA Co., Ltd. >> Hochiminh, Vietnam**  
Address: 41 Nguyen Thi Minh Khai Str. Yoco Bldg 4th Floor, Hochiminh City, Vietnam  
Tel: 84-8-3822-7941 Fax: 84-8-3822-7942 e-mail: hjchoid@lsis.biz
- **LSIS Shanghai Office >> Shanghai, China**  
Address: Room 32 floors of the Great Wall Building, No. 3000 North Zhongshan Road, Putuo District, Shanghai, China  
Tel: 86-21-5237-9977 Fax: 89-21-5237-7189 e-mail: baijh@lsis.com.cn
- **LSIS Beijing Office >> Beijing, China**  
Address: B-Tower 17FL.Beijing Global Trade Center B/D. No.36, BeiSanHuanDong-Lu, DongCheng-District, Beijing 100013, P.R. China  
Tel: 86-10-5825-6025.7 Fax: 86-10-5825-6026 e-mail: sunmj@lsis.com.cn
- **LSIS Guangzhou Office >> Guangzhou, China**  
Address: Room 1403, 14/F, New Poly Tower, No.2 Zhongshan Liu Road, Guangzhou 510180, P.R. China  
Tel: 020-8326-6754 Fax: 020-8326-6287 e-mail: chenxs@lsis.com.cn
- **LSIS Chengdu Office >> Chengdu, China**  
Address: Room 1701 17Floor, huamin hanjun international Building, No1 Fuxing Road Chengdu, 610016, P.R. China  
Tel: 86-28-8670-3201 Fax: 86-28-8670-3203 e-mail: yangcf@lsis.com.cn
- **LSIS Qingdao Office >> Qingdao, China**  
Address: Room 2001,20/F,7B40, Galaxy Building, No.29 Shandong Road, Shinan District, Qingdao 266071, P.R. China  
Tel: 86-532-8501-6058 Fax: 86-532-8501-6057 e-mail: wangzy@lsis.com.cn
- **LSIS NETHERLANDS Co.Ltd >> Schiphol-Rijk, Netherlands**  
Address: 1st. Floor, Tupolevlaan 48, 1119NZ,Schiphol-Rijk, The Netherlands  
Tel: 31-20-654-1420 Fax: 31-20-654-1429 e-mail: junshickp@lsis.biz
- **LSIS Gurgaon Office >> Gurgaon, India**  
Address: 109 First Floor, Park Central, Sector-30, Gurgaon- 122 002, Haryana, India e-mail: hwymj@lsis.biz

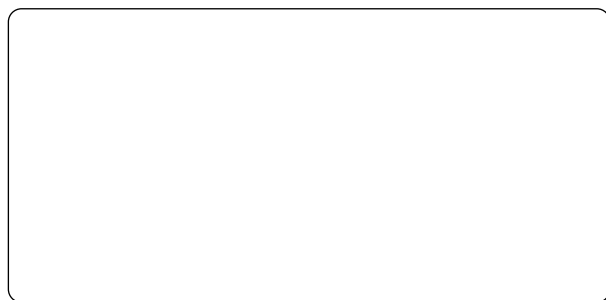

Specifications in this catalog are subject to change without notice due to continuous product development and improvement.