

Derwent
Top 100
Global
Innovator
2020

GIMAC1000

Digital Power Measuring Device

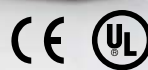

LS ELECTRIC



GIMAC1000

It is an advanced digital Power Measuring Device that enables power quality analysis such as high-precision measurement, harmonics, and THD measurement of various electric quantities of power distribution system.

GIMAC1000

Digital Power Measuring Device

- Various measurement elements and high precision measurement
 - Voltage, current : $\pm 0.3\%$
 - Power : Class0.5
- **Extended harmonic measurement range (31th harmonic)**
- Wide range of PT inputs (AC 10~452V)
- Incorrect wiring check function
- **Compact appearance design**
- Free Voltage Control Power
- Automatic Scroll Display of Measured Items
- RS-485, **Ethernet communication support**
- **Provide rapid spanning tree protocol function**

Contents

- 04 Features
- 05 Configuration
- 06 Rated specifications
- 08 Operation and Settings
- 10 Communication
- 11 Wiring
- 14 Dimensions and Ordering



Features



Various measurement elements and high precision measurement

The NO models can measure 14 measurement elements, while the EX models can measure 38 elements. The voltage satisfies $\pm 0.3\%$ (real scale) at rated voltage 10 ~ 452V, current is $\pm 0.3\%$ (full scale) at 0.05 ~ 6A, and power is class0.5. In particular, it ensures high reliability by maintaining precision even in the frequency fluctuating site.



Extended harmonic measurement range (31th harmonic)

Basic power quality measurement such as fundamental wave, harmonic and THD of electricity quantity is possible



Wide range of PT inputs (AC 10~452V)

It is economical and easy to wire because you can input AC10 ~ 452V directly without any PT.



Incorrect wiring check function

By detecting the direction of voltage rotation and judging whether there is an error in the wiring, the user can be notified of the PT wiring by notifying the user. Only three-phase four-wire and three-phase three-wire connections.



Compact appearance design

The basic model has an outline of 110 (W) x 110 (H) x 84.6 (D) mm and the panel cutting size is suitable for DIN 96 and ANSI 4.



Free Voltage Control Power

Control power can be used in various power environments.



Automatic Scroll Display of Measured Items

When you press the [DOWN] KEY (V) and [ENTER] KEY (↵) at the same time, the displayed item will automatically scroll every 10 seconds.



RS-485, Ethernet communication support

It supports MODBUS and TCP / IP protocol of RS-485 and Ethernet communication method.



Provide rapid spanning tree protocol function

Ethernet supports port redundancy and Rapid Spanning Tree Protocol for fast switching performance.

Front configuration

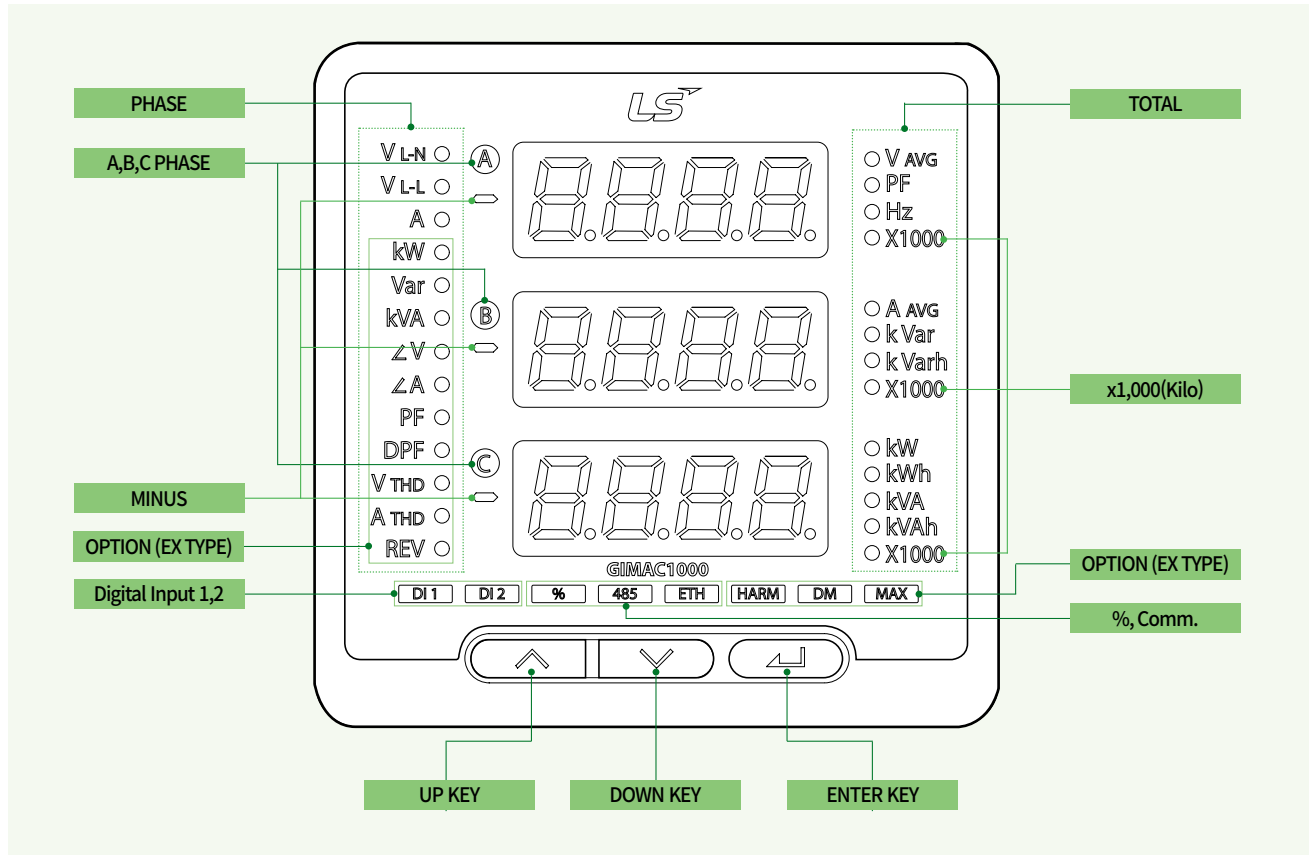

Rear configuration

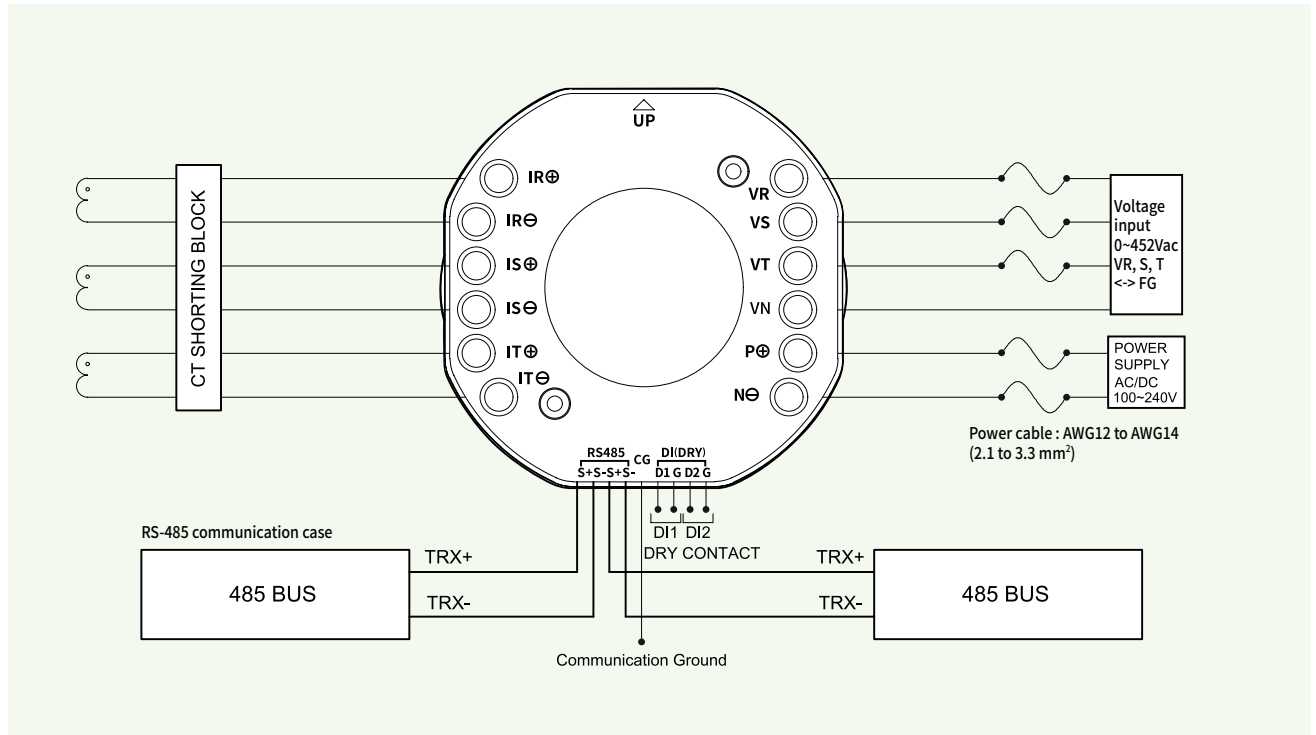

Rated specifications

Specification

Type		Specification	
Wiring		1P2W, 1P3W, 3P3W (Delta), 3P3W (Y), 3P4W	
Input	Frequency	50Hz, 60Hz	
	Voltage	PT	AC 10~452V (PT 2 nd 110V)
	Current	CT	0.05~6A (Rating : 5A) or 0.01~1.2A (Rating : 1A)
	Control voltage		AC/DC 100~240V (Free Voltage)
	power consumption		4.5W or less
	Burden		PT : 0.1VA or less CT : 0.5VA or less
Insulation Resistance		DC 500V 10MΩ or higher	
Insulation Voltage		AC 2kV(1kV)/for 1min	
Impulse Voltage		AC 5kV (3kV) or higher, 1.2 x 50μs Standard waveform	
Overload Withstand	Current circuit	Rated current x 1.2times for 3hours	
		Rated current x 8times for 2seconds	
	Voltage circuit	Rated voltage x 1.15times for 3hours	
Fast Transient/Burst Immunity		Power Input 4kV (PT, CT)	
Electrostatic Discharge		Air 8kV	
		Contact 6kV	
Operation temperature		-20°C ~ +60°C	
Storage Temperature		-25°C ~ +70°C	
Humidity		RH 80% or less (non-condensing)	
Certification		IEC60255, IEC61000-4	
Communication		MODBUS RTU/RS485, MODBUS TCP/IP ETHERNET	
Dimension (W×H×D)		110×110×84.6 mm (basic), 110×110×106.6 mm (ETHERNET TYPE)	
Weight		0.52kg	



Measurement

Parameters		NO	EX	Accuracy (%)	Remarks
Voltage	V_{avg}	■	■	±0.3%	-
	V_{ab}, V_{bc}, V_{ca}	■	■	±0.3%	-
	V_a, V_b, V_c	■	■	±0.3%	-
Current	I_{avg}	■	■	±0.3%	-
	I_a, I_b, I_c	■	■	±0.3%	-
	Load factor I_a, I_b, I_c	■	■	-	-
Phase	$\angle V_{ab}V_{bc}, \angle V_{ab}V_{ca}$	-	■	±0.5°	3P 3W
	$\angle V_{ab}I_a, \angle V_{ab}I_b, \angle V_{ab}I_c$	-	■	±0.5°	3P 3W
	$\angle V_aV_b, \angle V_aV_c$	-	■	±0.5°	3P 4W
	$\angle V_aI_a, \angle V_bI_b, \angle V_cI_c$	-	■	±0.5°	3P 4W
Power	P	■	■	Class0.5	IEC1036
	P_a, P_b, P_c	-	■	Class0.5	IEC1036
	Q	■	■	Class0.5	IEC1036
	Q_a, Q_b, Q_c	-	■	Class0.5	IEC1036
	S	■	■	Class0.5	IEC1036
	S_a, S_b, S_c	-	■	Class0.5	IEC1036
Power	Wh	■	■	Class0.5	IEC1036
	Varh	■	■	Class0.5	IEC1036
	rWh	-	■	Class0.5	IEC1036
	rVarh	-	■	Class0.5	IEC1036
	VAh	■	■	Class0.5	IEC1036
frequency	F	■	■	±0.05Hz	-
Power factor	PF	■	■	Based on phase error	+ : Lag - : Lead
	PF_a, PF_b, PF_c	-	■	Based on phase error	
	DPF_a, DPF_b, DPF_c	-	■	Based on phase error	
THD	$V_{a(ab)}, V_{b(bc)}, V_{c(ca)}$ THD	-	■	-	-
	I_a, I_b, I_c THD	-	■	-	-
Hamonics	$V_{a(ab)}, V_{b(bc)}, V_{c(ca)}$ 1st ~ 31th	-	■	-	-
	I_a, I_b, I_c 1st ~ 31th hamonics	-	■	-	-
DEMAND	Demand W	-	■	-	-
	Demand I_a, I_b, I_c, I_{avg}	-	■	-	-
MAX	$\max I_a, \max I_b, \max I_c, \max I_{avg}$	-	■	-	-
	$\max V_{a(ab)} \text{ THD}, \max V_{b(bc)} \text{ THD}$	-	■	-	-
	$\max V_{c(ca)} \text{ THD}$	-	■	-	-
	$\max I_a \text{ THD}, \max I_b \text{ THD},$ $\max I_c \text{ THD}$	-	■	-	-
	max W	-	■	-	-
	max VAR	-	■	-	-
	max VA	-	■	-	-
	max Demand I_{avg}, I_a, I_b, I_c	-	■	-	-
	max Demand W	-	■	-	-

Operation and Settings

The GIMAC1000 have a display mode and a setting mode.

Display Mode

- Move between pages is  key, Move between factor is   key
- See the measurement table on page 7 for details on pages and measurement items.

[Page]









1page total measurement factor : voltage, current, phase, power, frequency, power factor

2page THD : voltage, current 1st~31th

3page DEMAND : active power, current

4page MAX : current, voltage/current THD, active/reactive power, DEMAND

Setup Mode

- If you press   keys at the same time in the 'display mode', you will move to the 'setup mode'.
- The initial screen of 'setup mode' displays 'CONN' which indicates the wiring method.
- Move between setting items using   key.
- Change the value using   key and press  to save.
- When all settings are completed, press the   keys at the same time to return to the 'display mode'.

* If there is no operation for more than 3 minutes in 'setup mode', it automatically returns to 'display mode'.



Setup parameter

Order of display	Setup menu	Display	Value	Default	Remarks
1	Wiring	'CONN'	1: 1P 2W 2: 1P 3W 3: 3P 3W-D 4: 3P 3W-Y 5: 3P 4W	5	
2	PT Ratio	'Pt'	1.0000~1400.0000	1	1 st / 2 nd Magnification Input 1 input for direct connection
3	CT Ratio	'Ct'	1~2000(5A) or 1~9999(1A)		
4	DEMAND time	'dE.t'	1~60	15	Step 5(1~5 Step 1)
5	Communication Address	'Addr'	1~247	1	
6	Communication speed	'bPS'	1: 9600 bps 2: 19200 bps 3: 38400 bps	3	
	Float variable & swap	'S'	On: Yes Off: No	On	
7	Tx delay time	'tX.t'	10~200 msec	20	
8	IP Address	'tCP' 'Adr.'	1.0.0.0~233.255.255.255	192.168.0.100	
9	Subnet Mask	'tCP' 'Sub.'	0.0.0.0~255.255.255.255	255.255.255.0	
10	Gateway	'tCP' 'GAt.'	1.0.0.0~223.255.255.255	192.168.0.1	
11	Mac Address	'C-Ad'	00-00-00-FF-FF-FF	-	Not Available
12	TCP Idle Time	'id.t'	10~60 sec	10	
13	TCP SWAP	'tCP' 'S'	On: Yes Off: No	On	
14	DI1 Debounce time	'dEb' '1'	10~200	10	
15	DI2 Debounce time	'dEb' '2'	10~200	10	
16	RS485 Termination Switch	'tEr'	On: Yes Off: No	Off	
17	Data Reset	'rSt.'	0: All Data Reset 1: Wh Reset 2: Varh Reset 3: VAh Reset 4: rWh Reset 5: rVarh Reset 6: Demand A Reset 7: Demand W Reset 8: Max A Reset 9: Max W Reset 10: Max Var Reset 11: Max VA Reset 12: Max V THD Reset 13: Max A THD Reset 14: Max Demand A Reset 15: Max Demand W Reset 16: DI1 Counter Reset 17: DI2 Counter Reset	-	4~15: EX type only
18	LED TEST	'LEd' 'tEst'	On: Yes Off: No	Off	When setting value 'On', then all LEDs light for 2 seconds
19	Version display	'vEr.'	XX.XX / X.X	-	Not Available

Communication

1) Protocol

Type	Item	Specifications	Remarks
MODBUS/RS485	Operation mode	Differential	
	Baud rate	9600, 19200, 38400bps	
	Distance	Max. 1.2km	
	Cable spec.	Standard RS485 Shielded twisted pair cable	
	Transmission	Half-Duplex	
	Max. number of connections	Max. 32ea	
MODBUS/Ethernet	Topology	RSTP (Star, Daisy-Chain, Ring)	
	Communication speed	10/100Mbps	
	Distance	Max. 100m (between HUB to Terminal)	
	Cable spec.	UTP(CAT.3, CAT.5)	

2) MODBUS/RS485

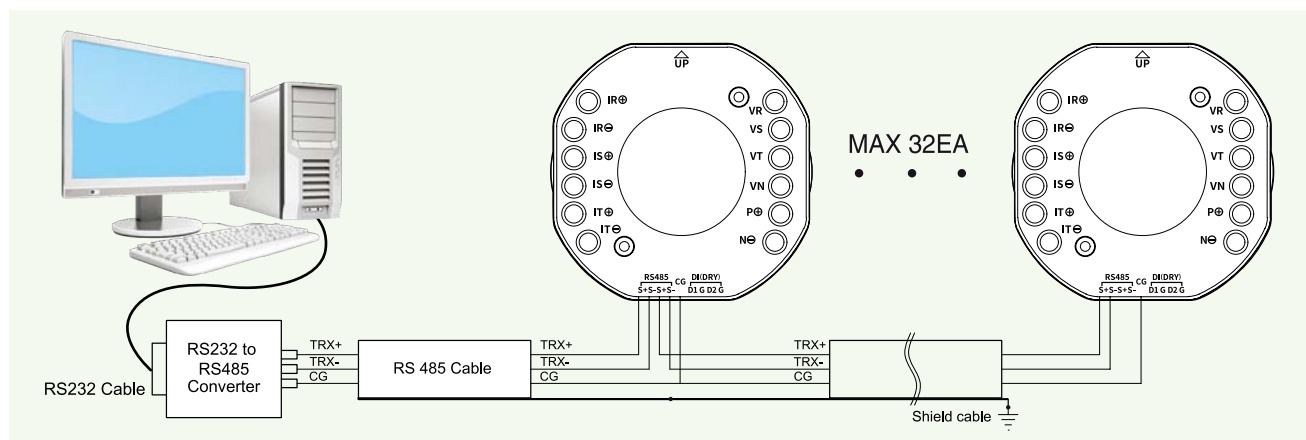

- VN terminal of the product must be grounded.
※ CAUTION) If the VN terminal is not grounded, the internal communication driver may be damaged.
- Shield of communication cable must be connected to each other and grounded.
- The CG terminals of the products must be connected to each other for the same potential and never connect the CG terminal to earth ground.
※ CAUTION) if the CG of communication cable be grounded, Internal components may be damaged.
- For the product connected at the end of communication, turn on the RS485 termination switch setting.
- 485 LED blinks in response to communication.

3) MODBUS/Ethernet

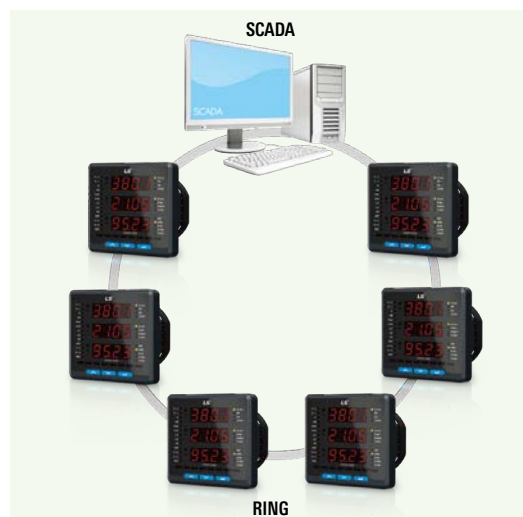

1P 2W

The range of voltage that can be directly connected without PT is 10 ~ 380V (+ 120%) based on phase voltage.
 The value of 1-phase 2-wire setting value in the wiring setting mode is "1".

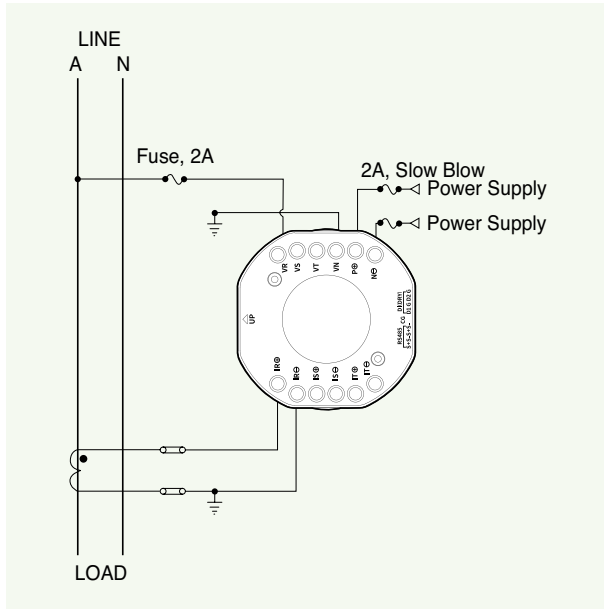

1-phase 2-wire direct connection

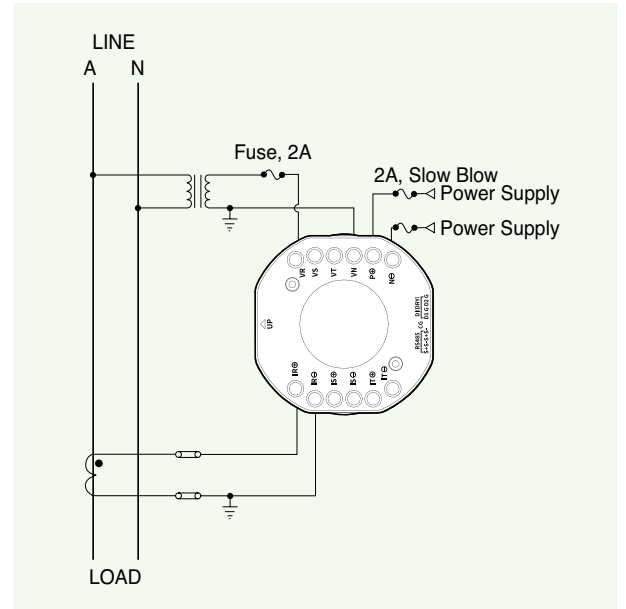

1-phase 2-wire connection with PT

1P 3W

The range of voltage that can be directly connected without PT is 10 ~ 380V (+ 120%) based on phase voltage.
 The value of 1-phase 3-wire setting value in the wiring setting mode is "2".

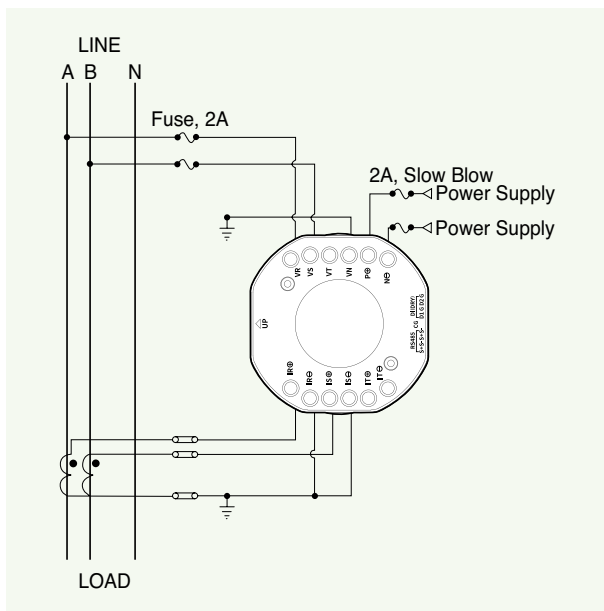

1-phase 3-wire direct connection

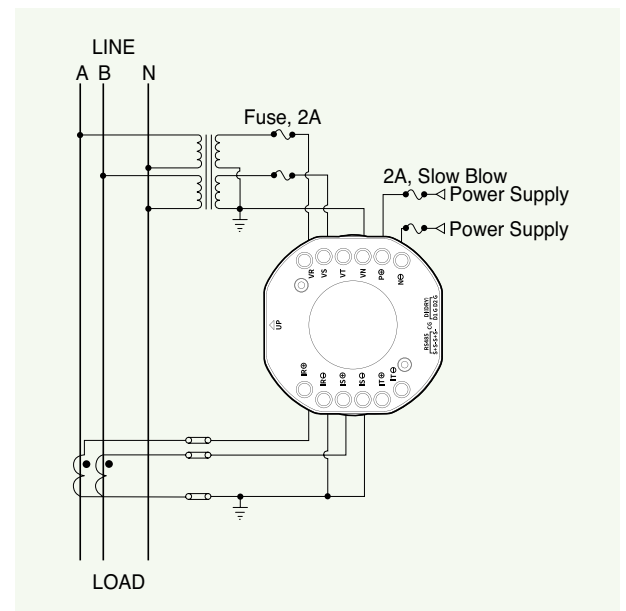

1-phase 3-wire connection with PT

Wiring

3P 3W-Y

The range of voltage that can be directly connected without PT is 17.3 ~ 658.2V based on line voltage.
 The value of 3-phase 3-wire Y type setting value in the wiring setting mode is "4".

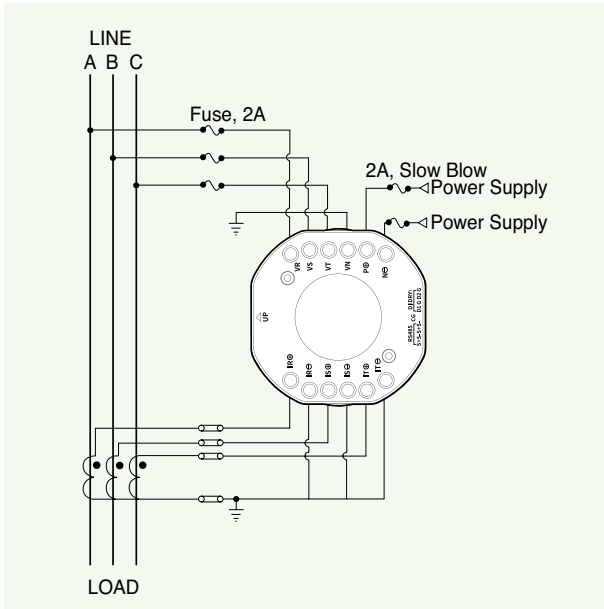

3-phase 3-wire direct connection

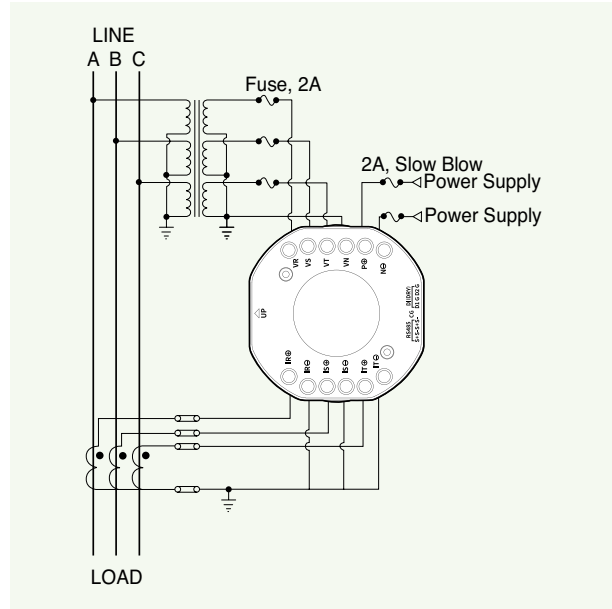

3-phase 3-wire Y connection with 3PT

3P 3W-Open Delta

The value of 3-phase 3-wire Delta type setting value in the wiring setting mode is "3".

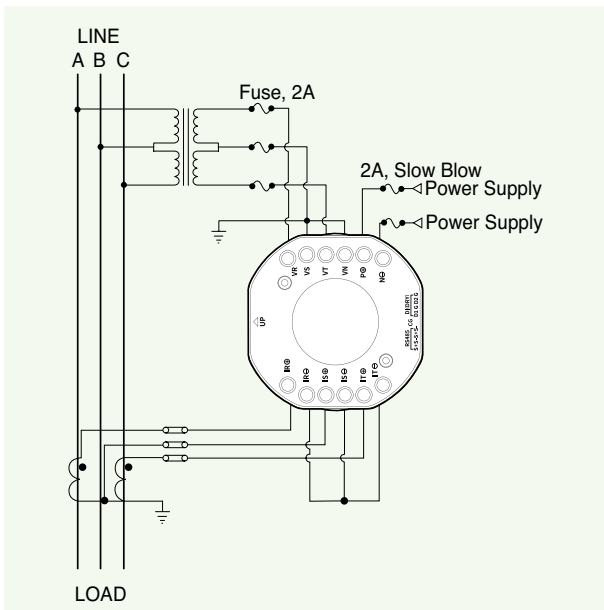

3-phase 3-wire Delta connection with 2PT and 2CT

- When 2PT is used, the V_{ca} voltage is obtained by the combination of V_{ab} and V_{cb} . Therefore, if the voltage is unbalanced, the voltage of V_{ca} causes an error.
- When 2CT is used, the I_S current is obtained by the combination of I_A and I_C . Therefore, if the current is unbalanced, the current of I_B causes an error.
- In case of unbalanced load, error occurs in power, so use it in case of balanced load.
- Each phase power (active, reactive, apparent), voltage/current phase, each phase power factor, and each phase fundamental power factor cannot be measured or displayed.

3P 4W Wiring

The range of voltage that can be directly connected without PT is 10 ~ 380V(+120%) based on phase voltage.
 The value of 3-phase 4-wire setting value in the wiring setting mode is "5".

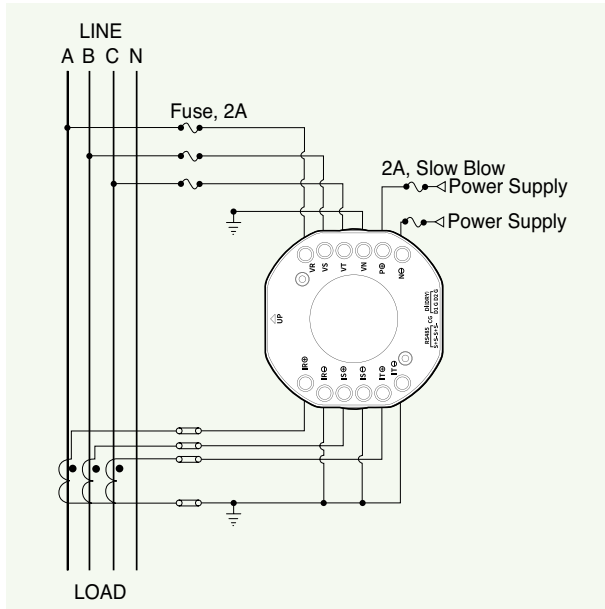

3-phase 4-wire direct connection

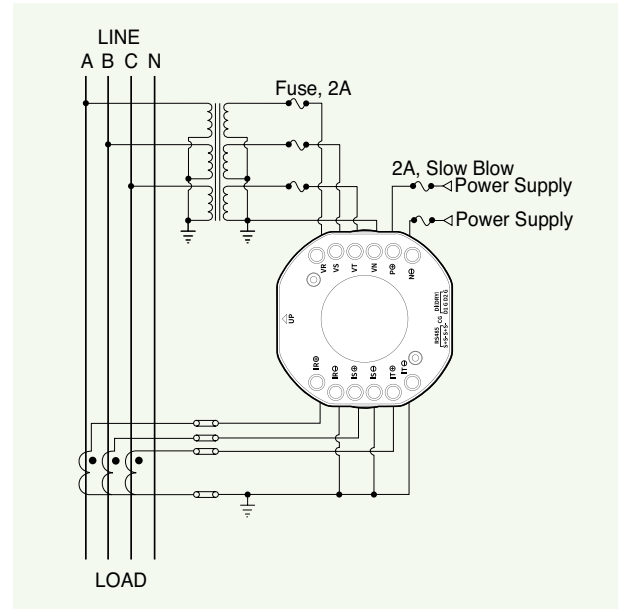

3-phase 4-wire connection with 3PT

Incorrect wiring

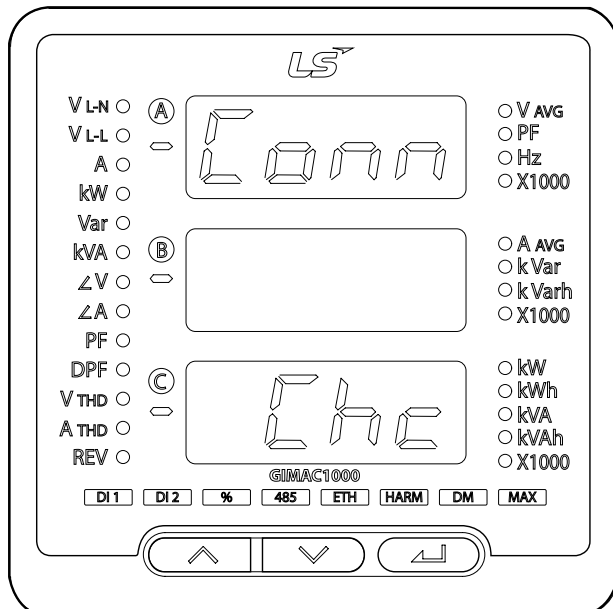

<Wiring Check>

The following message occurs in 3-phase 4-wire and 3-phase 3-wire-Y.
 Press the [ENTER] key to return to the measurement display mode.
 In case of [Conn Chc] message, check the wiring status.

Self diagnosis function & LCD display

ERROR	FND display
MEMORY	ERROR1
OPTION	ERROR3
Setting Data	ERROR4

Dimensions and Ordering

Dimensions

► NOCOMM/M485 TYPE

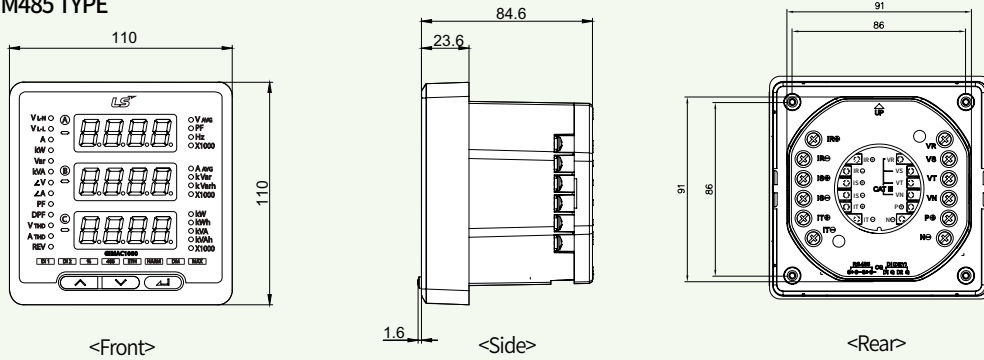

► ETHERNET TYPE

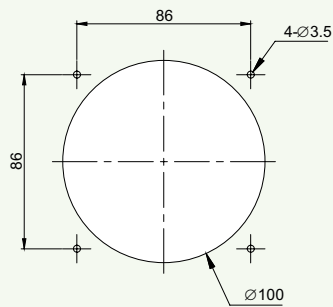
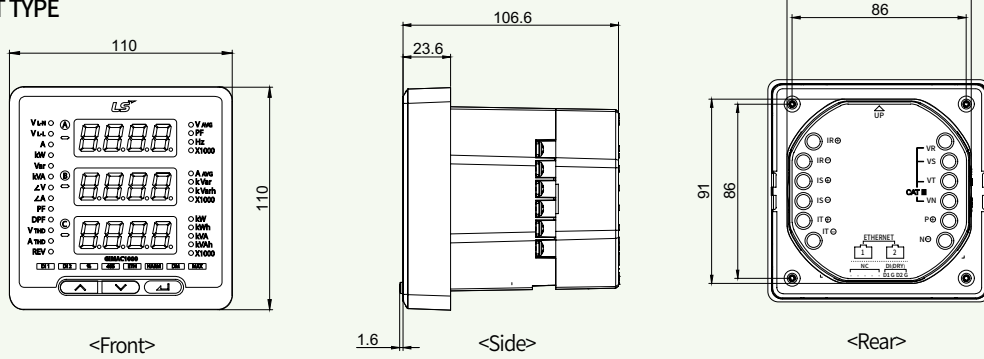

ANSI 4 Cutting Size

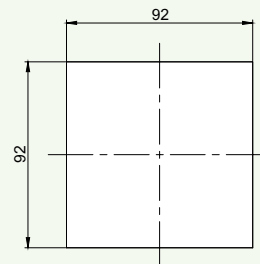

DIN 96 Cutting Size

• Panel cutting shape can be processed by selecting round or square.

Ordering

GIMAC1000

Model	Communication	CT Rating	Frequency	Control Power
NO Basic	- N/A	5A	60Hz	AC/DC 100~240V
EX Expansion	M485 MOD/RS485	1A	50Hz	
	ETH MOD TCP/ Ethernet			



Safety Instructions

- For your safety, please read user's manual thoroughly before operating.
- Contact the nearest authorized service facility for examination, repair, or adjustment.
- Please contact qualified service technician when you need maintenance. Do not disassemble or repair by yourself!
- Any maintenance and inspection shall be performed by the personnel having expertise concerned.



- According to The WEEE Directive, please do not discard the device with your household waste.



www.lselectric.co.kr

■ **Headquaters**

127, LS-ro(hogye-dong) Dongan-gu, Anyang-si, Gyeonggi-Do, 14119, Korea

■ **Seoul Office**

LS Yongsan Tower, 92, Hangang-daero, Yongsan-gu, Seoul, 04386, Korea
Tel: 82-2-2034-4916, 4684, 4429

■ **Overseas Subsidiaries**

- **LS ELECTRIC Japan Co., Ltd. (Tokyo, Japan)**
Tel: 81-3-6268-8241 E-Mail: jschuna@lselectric.biz
- **LS ELECTRIC (Dalian) Co., Ltd. (Dalian, China)**
Tel: 86-411-8730-5872 E-Mail: jiheo@lselectric.com.cn
- **LS ELECTRIC (Wuxi) Co., Ltd. (Wuxi, China)**
Tel: 86-510-6851-6666 E-Mail: jdyim@lselectric.com.cn
- **LS ELECTRIC Vietnam Co., Ltd.**
Tel: 84-93-631-4099 E-Mail: jhchoi4@lselectric.biz (Hanoi)
Tel: 84-28-3823-7890 E-Mail: sjbaik@lselectric.biz (Hochiminh)
- **LS ELECTRIC Middle East FZE (Dubai, U.A.E.)**
Tel: 971-4-886-5360 E-Mail: hschoib@lselectric.biz
- **LS ELECTRIC Europe B.V. (Hoofddorf, Netherlands)**
Tel: 31-20-654-1424 E-Mail: europartner@lselectric.biz
- **LS ELECTRIC America Inc. (Chicago, USA)**
Tel: 1-800-891-2941 E-Mail: sales.us@lselectricamerica.com

■ **Overseas Branches**

- **LS ELECTRIC Tokyo Office (Japan)**
Tel: 81-3-6268-8241 E-Mail: jschuna@lselectric.biz
- **LS ELECTRIC Beijing Office (China)**
Tel: 86-10-5095-1631 E-Mail: chendm@lselectric.com.cn
- **LS ELECTRIC Shanghai Office (China)**
Tel: 86-21-5237-9977 E-Mail: khpaek@lselectric.com.cn
- **LS ELECTRIC Guangzhou Office (China)**
Tel: 86-20-3818-2883 E-Mail: chenxs@lselectric.com.cn
- **LS ELECTRIC Chengdu Office (China)**
Tel: 86-28-8670-3201 E-Mail: yangcf@lselectric.com.cn
- **LS ELECTRIC Qingdao Office (China)**
Tel: 86-532-8501-2065 E-Mail: wangzy@lselectric.com.cn
- **LS ELECTRIC Nanjing Office (China)**
Tel: 86-25-8467-0005 E-Mail: ylong@lselectric.com.cn
- **LS ELECTRIC Bangkok Office (Thailand)**
Tel: 66-90-950-9683 E-Mail: sjleet@lselectric.biz
- **LS ELECTRIC Jakarta Office (Indonesia)**
Tel: 62-21-2933-7614 E-Mail: jylee@lselectric.biz
- **LS ELECTRIC Moscow Office (Russia)**
Tel: 7-499-682-6130 E-Mail: jdpark1@lselectric.biz
- **LS ELECTRIC America Western Office (Irvine, USA)**
Tel: 1-949-333-3140 E-Mail: jwyun@lselectricamerica.com



Technical Question or After-sales Service

Customer Center-Quick Responsive Service, Excellent technical support | **82-1644-5481**