



**SIPROTEC**  
**Numerical Protection Relays**  
**7RW600 UV/OV & Frequency**

Protection  
Systems  
Catalog  
SIP · 2004

**SIEMENS**

## *SIPROTEC – more than just protection*

This is the latest edition of the printed SIPROTEC Catalog. This edition - which is now available - contains many suggestions by our readers, along with information regarding innovations and supplementary products. The SIPROTEC Catalog is also available on CD ROM.

One of the new highlights is the SIPROTEC protection relays with IEC 61850 communication. IEC 61850 was created by relay experts and manufacturers alike. The goal of this standard is to achieve an object-oriented communication structure within substations. SIPROTEC protection relays and bay control units are the first to feature the IEC 61850 standard. With the substation configurator, a part of DIGSI 4, SIPROTEC units as well as other makes can be configured in accordance with IEC 61850.

Meet the standard

**IEC 61850**

This SIPROTEC Catalog is supplemented by multimedia computer animation tools.

+ CD-ROM “SIPROTEC 4 you – Features, Applications, Relays”

+ CD-ROM “SIPROTEC 4 you – Start Up”.

+ CD-ROM “SIPROTEC 4 you – IEC 61850 & ETHERNET”.

You can order the printed SIPROTEC Catalog (and all the CD ROMs) via the Internet free of charge. Please fill in a form at [www.siprotec.com/catalog](http://www.siprotec.com/catalog). You may also consult your Siemens representative or send us an e-mail ([support@ptd.siemens.de](mailto:support@ptd.siemens.de)).

This catalog will assist you by increasing your understanding of our products and therefore help you to optimally and conveniently utilize the available features and functionality. We wish you a pleasant and productive experience with SIPROTEC.

Bernhard W. Niessing  
Vice President  
Protection and Power Quality



**ONE bay, ONE IED** (Intelligent Electronic Device) Siemens is the world market leader in delivering combined protection & control relays. We provide control functionality with the CFC (Continuous function chart), which is accepted as state-of-art in industrial automation (SIMATIC STEP 7) and makes the life for the protection engineers easier.



**ONE DIGSI** Parameterisation - Software serves all products Siemens is the first supplier to meet this strong customer demand to have one software for all protection products. DIGSI can handle previous versions and the bus-bar protection while providing unrivalled functionality.



**ONE single source** for all products and services Siemens provides a full product range for all market segments. In order to provide optimal services we have concentrated resources for important functions, e.g. one product management, one product development, one factory, etc. We will support you in planning, engineering, commissioning, relay co-ordination, type test, etc. all over the world.



# Product Selection Page

# Relay Functions

1

ANSI No.*	Description	Type	Distance			Pilot wire differential Line differential			Overcurrent				Differential											
			7SA513	7SA522	7SA6	7SD600	7SD5	7SD610	7SJ45	7SJ46	7SJ600	7SJ602	7SJ61	7SJ62	7SJ63	7SJ64	7VH60	7UT512	7UT513	7UT612	7UT613	7UT63	7SS60	7SS52
14	Locked rotor protection		-	-	-	-	-	-	-	-	-	-	-	-	-	-	-	-	-	-	-	-	-	-
21	Distance protection, phase		■	■	■	-	●	-	-	-	-	-	-	-	-	-	-	-	-	-	-	-	-	-
21N	Distance protection, earth (ground)		■	■	■	-	●	-	-	-	-	-	-	-	-	-	-	-	-	-	-	-	-	-
21FL	Fault locator		■	■	■	-	●	-	-	-	-	-	-	-	-	-	-	-	-	-	-	-	-	-
24	Overfluxing (V/f protection)		-	-	-	-	-	-	-	-	-	-	-	-	-	-	-	-	-	-	●	●	-	-
25	Synchronizing, synchronism check		●	●	●	-	●	-	-	-	-	-	-	-	-	-	-	-	-	-	-	-	-	-
27	Undervoltage		-	●	●	-	●	-	-	-	-	-	-	-	-	-	-	-	-	-	-	-	-	-
27/34	Stator earth fault 3 <sup>rd</sup> harmonic		-	-	-	-	-	-	-	-	-	-	-	-	-	-	-	-	-	-	-	-	-	-
32	Directional power		-	-	-	-	-	-	-	-	-	-	-	-	-	-	-	-	-	-	-	-	-	-
32F	Forward power		-	-	-	-	-	-	-	-	-	-	-	-	-	-	-	-	-	-	-	-	-	-
32R	Reverse power		-	-	-	-	-	-	-	-	-	-	-	-	-	-	-	-	-	-	-	-	-	-
37	Undercurrent or underpower		-	-	-	-	-	-	-	-	-	-	-	-	-	-	-	-	-	-	-	-	-	-
40	Loss of field		-	-	-	-	-	-	-	-	-	-	-	-	-	-	-	-	-	-	-	-	-	-
46	Load unbalance, negative phase-sequence overcurrent		-	-	-	-	-	-	-	-	-	-	-	-	-	-	-	-	-	-	-	-	-	-
47	Phase-sequence voltage		■	■	■	-	■	-	-	-	-	-	-	-	-	-	-	-	-	-	-	-	-	-
48	Motor starting protection		-	-	-	-	-	-	-	-	-	-	-	-	-	-	-	-	-	-	-	-	-	-
49	Thermal overload		-	-	●	-	■	■	-	-	-	-	-	-	-	-	-	-	-	-	-	-	-	-
49R	Rotor thermal protection		-	-	-	-	-	-	-	-	-	-	-	-	-	-	-	-	-	-	-	-	-	-
49S	Stator thermal protection		-	-	-	-	-	-	-	-	-	-	-	-	-	-	-	-	-	-	-	-	-	-
50	Instantaneous overcurrent		■	■	■	■	■	■	■	■	■	■	■	■	■	■	■	■	■	■	■	■	■	■
50N	Instantaneous earth fault overcurrent		■	■	■	-	■	■	-	-	-	-	-	-	-	-	-	-	-	-	-	-	-	-
50BF	Breaker failure		■	●	●	-	■	●	-	-	-	-	-	-	-	-	-	-	-	-	-	-	-	-
51GN	Zero speed and underspeed device		-	-	-	-	-	-	-	-	-	-	-	-	-	-	-	-	-	-	-	-	-	-
51	Overcurrent-time relay, phase		■	■	■	■	■	■	■	■	■	■	■	■	■	■	■	■	■	■	■	■	■	■
51N	Overcurrent-time relay, earth		■	■	■	-	■	■	■	■	■	■	■	■	■	■	■	■	■	■	■	■	■	■
51V	Overcurrent-time relay, voltage controlled		-	-	-	-	-	-	-	-	-	-	-	-	-	-	-	-	-	-	-	-	-	-
59	Overvoltage		■	●	●	-	●	-	-	-	-	-	-	-	-	-	-	-	-	-	-	-	-	-
59N	Residual voltage earth fault protection		●	●	●	-	●	-	-	-	-	-	-	-	-	-	-	-	-	-	-	-	-	-
59GN	Stator earth-fault protection		-	-	-	-	-	-	-	-	-	-	-	-	-	-	-	-	-	-	-	-	-	-
64	100 % Stator earth-fault protection (20 Hz)		-	-	-	-	-	-	-	-	-	-	-	-	-	-	-	-	-	-	-	-	-	-
64R	Rotor earth fault		-	-	-	-	-	-	-	-	-	-	-	-	-	-	-	-	-	-	-	-	-	-

- Standard function
- Option

\* ANSI/IEEE C 37.2: IEEE Standard Electrical Power System Device Function Numbers

Protection functions	Type	Generator protection				Generator and motor protection		Breaker management Auto-reclosure + synchronism check Synchronizing		Breaker failure		Voltage, frequency		
		7UM511	7UM512	7UM515	7UM516	7UM61	7UM62	7VK61	7VK512	7VE51	7VE6		7SV512	7SV600
ANSI No.*	Description													
14	Locked rotor protection	-	-	-	-	■	■	-	-	-	-	-	-	-
21	Distance protection, phase	-	-	-	■	■	■	-	-	-	-	-	-	-
21N	Distance protection, earth	-	-	-	-	-	-	-	-	-	-	-	-	-
21FL	Fault locator	-	-	-	-	-	-	-	-	-	-	-	-	-
24	Overfluxing ( $V/f$ protection)	-	-	■	-	■	■	-	-	-	-	-	-	■
25	Synchronizing, synchronism check	-	-	-	-	-	-	■	■	■	■	-	-	-
27	Undervoltage	■	-	■	-	■	■	●	-	-	●	-	-	■
27/34	Stator earth fault 3 <sup>rd</sup> harmonic	-	■	-	-	■	■	-	-	-	-	-	-	-
32	Directional power	■	■	-	-	-	■	-	-	-	-	-	-	-
32F	Forward power	-	-	-	■	●	■	-	-	-	-	-	-	-
32R	Reverse power	-	-	-	■	■	■	-	-	-	-	-	-	-
37	Undercurrent or underpower	-	■	-	-	-	■	-	-	-	-	-	-	-
40	Loss of field	■	■	-	■	●	■	-	-	-	-	-	-	-
46	Load unbalance, negative phase-sequence overcurrent	■	■	-	■	●	●	-	-	-	-	-	-	-
47	Phase-sequence voltage	-	-	-	-	■	■	-	-	-	-	-	-	-
48	Incomplete sequence, locked rotor	-	-	-	-	●	●	-	-	-	-	-	-	-
49	Thermal overload	■	-	-	-	■	■	-	-	-	-	-	-	-
49R	Rotor thermal protection	-	-	-	-	-	-	-	-	-	-	-	-	-
49S	Stator thermal protection	■	-	-	-	■	■	-	-	-	-	-	-	-
50	Instantaneous overcurrent	-	-	-	-	■	■	-	-	-	-	-	-	-
50N	Instantaneous earth-fault overcurrent	-	-	-	-	■	■	-	-	-	-	-	-	-
50BF	Breaker failure	-	-	-	-	■	■	-	-	-	-	■	■	-
51GN	Zero speed and underspeed dev.	-	-	-	-	-	■	-	-	-	-	-	-	-
51	Overcurrent-time relay, phase	■	■	-	-	■	■	-	-	-	-	-	-	-
51N	Overcurrent-time relay, earth	-	-	-	-	■	■	-	-	-	-	-	-	-
51V	Overcurrent-time relay, voltage controlled	■	■	-	-	■	■	-	-	-	-	-	-	-
59	Overvoltage	■	■	■	-	■	■	●	-	-	●	-	-	■
59N	Residual voltage earth-fault protection	■	-	-	-	■	■	-	-	-	-	-	-	-
59GN	Stator earth-fault protection	-	■	■	-	■	■	-	-	-	-	-	-	-
64	100 % Stator earth-fault protection (20 Hz)	-	■	■	-	-	●	-	-	-	-	-	-	-
64R	Rotor earth fault	-	■	■	-	■	■	-	-	-	-	-	-	-

■ Standard function

● Option

\* ANSI/IEEE C 37.2: IEEE Standard Electrical Power System Device Function Numbers

# Relay Functions

1

Protection functions	Type	Distance			Pilot wire differential Line differential			Overcurrent							Differential									
		7SA513	7SA522	7SA6	7SD600	7SD5	7SD610	7SJ45	7SJ46	7SJ600	7SJ602	7SJ61	7SJ62	7SJ63	7SJ64	7VH60	7UT512	7UT513	7UT612	7UT613	7UT63	7SS60	7SS52	
ANSI No.*	Description																							
67	Directional overcurrent	-	-	-	-	-	-	-	-	-	-	-	-	-	-	-	-	-	-	-	-	-	-	-
67N	Directional earth-fault overcurrent	●	●	●	-	●	-	-	-	-	-	-	-	-	-	-	-	-	-	-	-	-	-	-
67G	Stator earth-fault directional overcurrent	-	-	-	-	-	-	-	-	-	-	-	-	-	-	-	-	-	-	-	-	-	-	-
68	Out-of-step protection	■	●	●	-	●	-	-	-	-	-	-	-	-	-	-	-	-	-	-	-	-	-	-
74TC	Trip circuit supervision	-	■	■	-	■	■	-	-	-	■	■	■	■	■	■	■	-	-	●	●	●	-	-
78	Out-of-step protection	-	-	-	-	-	-	-	-	-	-	-	-	-	-	-	-	-	-	-	-	-	-	-
79	Auto-reclosure	●	●	●	-	●	●	-	-	-	●	●	●	●	●	●	●	-	-	-	-	-	-	-
81	Frequency protection	-	■	■	-	●	-	-	-	-	-	-	-	-	●	●	●	-	-	-	-	-	-	-
81R	Rate of frequency change protection	-	-	-	-	-	-	-	-	-	-	-	-	-	-	-	-	-	-	-	-	-	-	-
	Vector jump supervision	-	-	-	-	-	-	-	-	-	-	-	-	-	-	-	-	-	-	-	-	-	-	-
85	Carrier interface/remote trip	■	■	■	●	■	■	-	-	-	-	-	-	-	-	-	-	-	-	-	-	-	-	■
86	Lockout function	-	■	■	■	■	■	-	-	-	-	-	-	-	■	■	■	■	-	-	-	-	-	-
87G	Differential protection generator	-	-	-	-	-	-	-	-	-	-	-	-	-	-	-	-	-	-	-	-	-	-	-
87T	Differential protection transformer	-	-	-	■	●	●	-	-	-	-	-	-	-	-	-	-	-	-	-	-	-	-	-
87BB	Differential protection busbar	-	-	-	-	-	-	-	-	-	-	-	-	-	-	-	-	-	-	-	-	-	-	-
87M	Differential protection motor	-	-	-	-	-	-	-	-	-	-	-	-	-	-	-	-	-	-	-	-	-	-	-
87L	Differential protection line	-	-	-	■	■	■	-	-	-	-	-	-	-	-	-	-	-	-	-	-	-	-	-
87N	Restricted earth-fault protection	-	-	-	-	-	-	-	-	-	-	-	-	-	■	■	■	■	■	■	■	-	-	-

■ Standard function

● Option

\* ANSI/IEEE C 37.2: IEEE Standard Electrical Power System Device Function Numbers

Protection functions	Type	Generator protection		Generator and motor protection		Breaker management Auto-reclosure + synchronism check Synchronizing		Breaker failure		Voltage, frequency				
		7UM511	7UM512	7UM515	7UM516	7UM61	7UM62	7VK61	7VK512		7VE51	7VE6	7SV512	7SV600
ANSI No.*	Description													
67	Directional overcurrent	-	-	-	■	■	-	-	-	-	-	-	-	-
67N	Directional earth-fault overcurrent	-	-	-	■	■	-	-	-	-	-	-	-	-
67G	Stator earth-fault directional overcurrent	-	-	-	■	■	-	-	-	-	-	-	-	-
68	Out-of-step protection	-	-	■	-	●	-	-	-	-	-	-	-	-
74TC	Trip circuit supervision	-	-	-	■	■	■	-	-	-	-	-	-	-
78	Out-of-step protection	-	-	■	-	■	-	-	-	-	-	-	-	-
79	Auto-reclosure	-	-	-	-	-	■	■	-	-	-	-	-	-
81	Frequency protection	■	■	■	-	■	-	-	-	●	-	-	-	■
81R	Rate of frequency change protection	-	-	-	-	●	-	-	-	●	-	-	-	●
	Vector jump supervision	-	-	-	-	●	-	-	-	●	-	-	-	-
85	Carrier interface/remote trip	-	-	-	-	-	-	-	-	-	-	-	-	-
86	Lockout function	-	-	-	-	■	■	■	-	●	-	-	-	-
87G	Differential protection generator	-	-	-	-	■	-	-	-	-	-	-	-	-
87T	Differential protection transformer	-	-	-	-	■	-	-	-	-	-	-	-	-
87BB	Differential protection busbar	-	-	-	-	-	-	-	-	-	-	-	-	-
87M	Differential protection motor	-	-	-	-	■	-	-	-	-	-	-	-	-
87L	Differential protection line	-	-	-	-	-	-	-	-	-	-	-	-	-
87N	Restricted earth-fault protection	-	-	-	-	●	-	-	-	-	-	-	-	-

■ Standard function  
● Option

\* ANSI/IEEE C 37.2: IEEE Standard Electrical Power System Device Function Numbers

## SIPROTEC 7RW600 Numerical Voltage, Frequency and Overexcitation Protection Relay

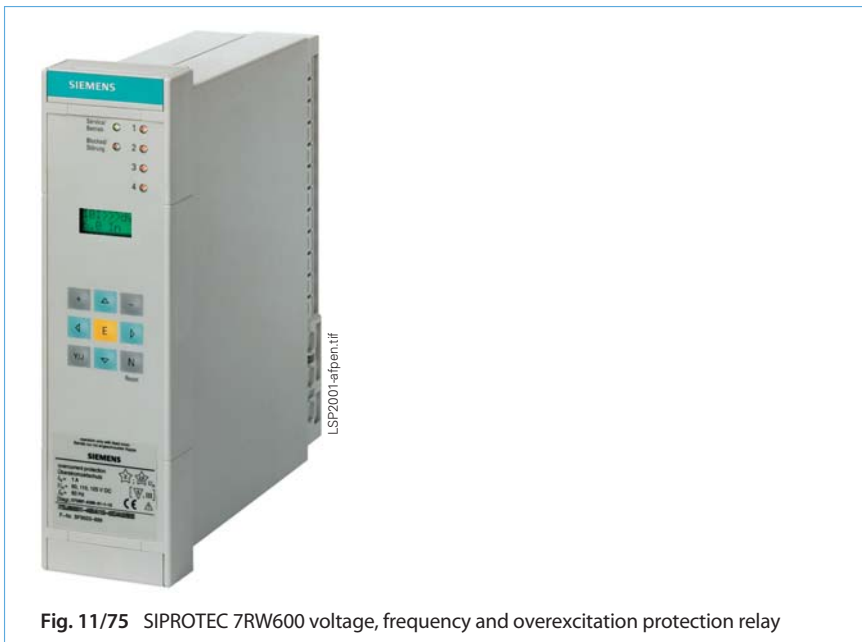

Fig. 11/75 SIPROTEC 7RW600 voltage, frequency and overexcitation protection relay

### Description

The SIPROTEC 7RW600 is a numerical multifunction protection relay for connection to voltage transformers. It can be used in distribution systems, on transformers and for electrical machines. If the SIPROTEC 7RW600 detects any deviation from the permitted voltage, frequency or overexcitation values, it will respond according to the values set. The SIPROTEC 7RW600 can be used for the purposes of system decoupling and for load shedding if ever there is a risk of a system collapse as a result of inadmissibly large frequency drops. Voltage and frequency thresholds can also be monitored.

The SIPROTEC 7RW600 voltage, frequency and overexcitation relay can be used to protect generators and transformers in the event of defective voltage control, of defective frequency control, or of full load rejection, or furthermore islanding generation systems.

This device is intended as a supplement to Siemens substation systems and for use in individual applications. It has two voltage inputs ( $V$ ;  $V_x$ ) to which a variety of functions have been assigned. While input  $V$  serves all of the implemented functions, input  $V_x$  is exclusively dedicated to the voltage protection functions. The scope of functions can be selected from three ordering options.

### Function overview

#### Line protection

- Voltage protection
- Frequency protection

#### Generator protection

- Voltage protection
- Frequency protection
- Overexcitation protection

#### Transformer protection

- Voltage protection
- Overexcitation protection

#### Power system decoupling

- Voltage protection
- Frequency protection

#### Load shedding

- Frequency protection
- Rate-of-frequency-change protection

#### Status measured values

#### Monitoring functions

- Hardware
- Software
- Event logging
- Fault recording
- Continuous self-monitoring

#### Hardware

- Auxiliary voltages:
  - 24, 48 V DC
  - 60, 110, 125 V DC
  - 220, 250 V DC, 115 V AC
- Local operation
- LCD for setting and analysis
- Housing for
  - Flush-mounting 1/6 19-inch 7XP20;
  - Surface-mounting 1/6 19-inch 7XP20

#### Communication ports

- Personal computer
- Via RS485 – RS232 converter
- Via modem
- SCADA
  - IEC 60870-5-103 protocol
- Bus-capable

**Application**

The SIPROTEC 7RW600 is a numerical multifunction protection relay for connection to voltage transformers. It can be used in distribution systems, on transformers and for electrical machines. If the SIPROTEC 7RW600 detects any deviation from the permitted voltage, frequency or overexcitation values, it will respond according to the values set. The SIPROTEC 7RW600 can be used for the purposes of system decoupling and for load shedding if ever there is a risk of a system collapse as a result of inadmissibly large frequency drops. Voltage and frequency thresholds can also be monitored.

The SIPROTEC 7RW600 voltage, frequency and overexcitation relay can be used to protect generators and transformers in the event of defective voltage control, of defective frequency control, or of full load rejection, or furthermore islanding generation systems.

**Applications**

ANSI	IEC	Protection functions
27	$V <, t; t = f(V <)$	Undervoltage protection
59 / 59N	$V >>, t; V >, t$	Overvoltage protection
81 / 81R	$f >; f <; \left  \frac{df}{dt} \right  >; + \frac{df}{dt}$	Frequency protection, rate-of-frequency-change protection
24	$\frac{V}{f} >, t; \frac{V}{f} = f(t)$	Overexcitation protection

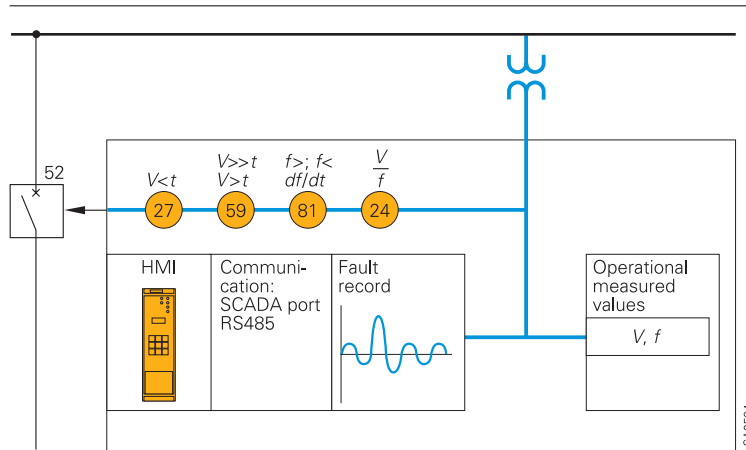

Fig. 11/76 Function diagram

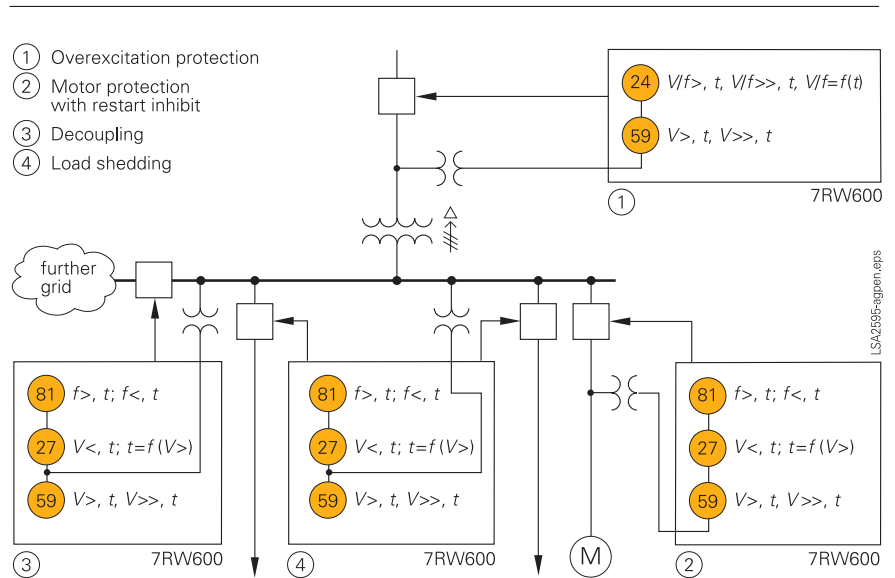

Fig. 11/77

## Construction

The SIPROTEC 7RW600 relay contains, in a compact form, all the components needed for:

- Acquisition and evaluation of measured values
- Operation and display
- Output of messages, signals and commands
- Input and evaluation of binary signals
- Data transmission (RS485) and
- Auxiliary voltage supply.

The SIPROTEC 7RW600 receives AC voltages from the primary voltage transformer. The secondary rated voltage range, 100 to 125 V, is adapted internally on the device.

There are two device variants available:

- The first version, for panel flush mounting or cubicle mounting, has its terminals accessible from the rear.
- The second version for panel surface mounting, has its terminals accessible from the front.



**Fig. 11/78**  
Rear view of surface-mounting case

## Protection functions

### Overvoltage protection

The overvoltage protection has the function of detecting inadmissible overvoltages in power systems and electrical machines and, in such event, it initiates system decoupling or shuts down the generators.

Two voltage measuring inputs ( $V$ ,  $V_x$ ) are provided on the unit. These must be connected to two phase-to-phase voltages. The input voltages are processed separately in two two-stage protective functions. From these, two principle connection variants are derived.

Fig. 11/81, Fig. 11/82, and Fig. 11/83, on page 11/83, show the following connection examples:

**Fig. 11/81:**

Separated connection, used for overvoltage protection and earth-fault detection

**Fig. 11/82:**

Two-phase connection to a voltage transformer

**Fig. 11/83:**

Alternative  $V$  connection

### Undervoltage protection

The main function of the undervoltage protection is protecting electrical machines (e.g. pumped-storage power generators and motors) against the consequences of dangerous voltage drops. It separates the machines from the power system and thus avoids inadmissible operating states and the possible risk of stability loss. This is a necessary criterion in system decoupling.

To ensure that the protection functions in a physically correct manner, when used in conjunction with electrical machines, the positive-sequence system must be evaluated.

The protection function can be blocked, via a binary input, causing a drop in energizing power. The auxiliary contact of the circuit-breaker can be used for this purpose with the circuit-breaker open. Alternatively, undervoltage acquisition can be activated on a conductor-separated basis ( $V < V_x < \dots$ ).

Additionally, it is possible to use an inverse-time undervoltage protection function for motor protection. The tripping time depends in the undervoltage drop. A time grading is possible.

### Frequency protection

The frequency protection can be used to protect against overfrequency or against underfrequency. It protects electrical machines and plants/substations against adverse effects in the event of deviations in the rated speed (e.g. vibration, heating, etc.), detects and records frequency fluctuations in the power system, and disconnects certain loads according to the thresholds set. It can also be used for the purposes of system decoupling, and thus improves the availability of in-plant power generation.

The frequency protection function is implemented via voltage input  $V$ . From the sampled voltage, the frequency is measured by means of various filter functions. The system thus remains unaffected by harmonics, ripple control frequencies and other disturbances.

The frequency protection function operates over a wide frequency range (25-70 Hz).

It is implemented (optionally for overfrequency or for underfrequency) on a four-stage basis; each stage can be individually delayed. The frequency stages can be blocked either via the binary input or by an undervoltage stage.

### Rate-of-frequency-change protection

The rate-of-frequency-change protection calculates, from the measured frequency, the gradient of frequency change  $df/dt$ . It is thus possible to detect and record any major active power overloading in the power system, to disconnect certain consumers accordingly, and to restore the system to stability. Unlike frequency protection, rate-of-frequency-change protection already reacts before the frequency threshold is undershot. To ensure effective protection settings, power system studies are recommended. The rate-of-frequency-change protection function can also be used for the purposes of system decoupling.

The rate-of-frequency-change protection function is implemented on a four-stage basis; each stage can be individually delayed. It detects and records any negative or positive frequency gradient. The measured result is generally released as soon as the rated frequency is undershot or overshot.

Rate-of-frequency-change protection can also be enabled by an underfrequency or overfrequency stage.

Protection functions

Overexcitation protection

The overexcitation protection detects and records any inadmissibly high induction

$$(B \sim \frac{V}{f})$$

in electrical equipment, e.g. generators or transformers, that may occur as a result of a voltage increase and/or frequency drop. Increased induction of this nature may lead to saturation of the iron core, excessive eddy current losses, and thus to inadmissible heating.

It is recommended to use the overexcitation protection function in power systems subject to large frequency fluctuations (e.g. systems in island configuration or with weak infeed) and for electrical block units that are separated from the system.

The overexcitation protection function calculates, from the maximum voltage ( $V_x$ ) and the frequency, the ratio  $V/f$ . This function incorporates an independent warning and tripping stage and a curve which is dependent on and adaptable to the object to be protected and which takes due account of the object's thermal behavior. Incorrect adaptation of the voltage transformer is also corrected. The overexcitation protection function is effective over a broad frequency range (25 to 70 Hz) and voltage range (10 to 170 V).

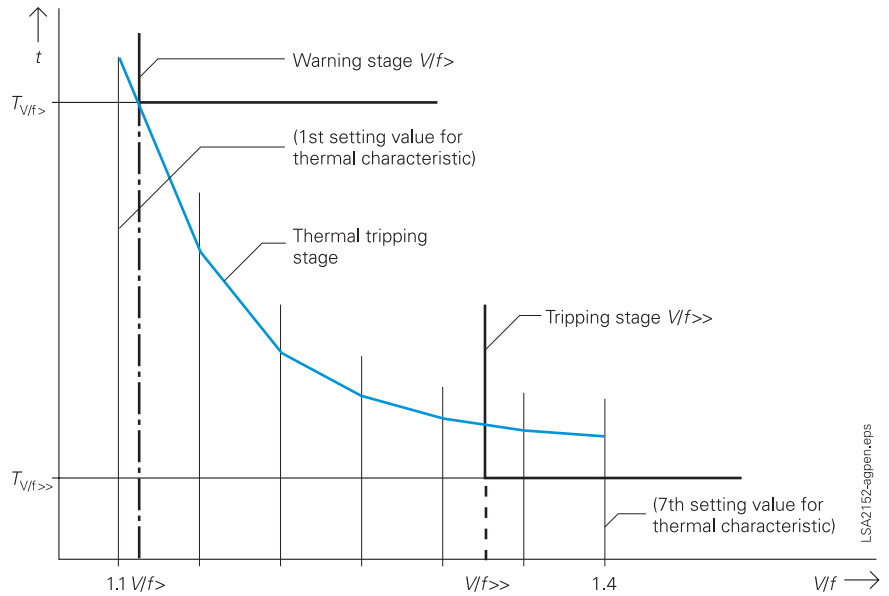

Fig. 11/79 Tripping range of overexcitation protection

Features

Serial data transmission

The SIPROTEC 7RW600 relay is fitted with an RS485 port, via which a PC can be connected, thus providing, in conjunction with the DIGSI operating and analysis program, a convenient tool for configuring and parameter setting. The DIGSI program (which runs under MS-Windows) also performs fault recording and fault evaluation. The SIPROTEC 7RW600 relay can also be linked, via the appropriate converters, either directly or over an optoelectronic connection (optical fiber) to the interface of the PC or substation control system (IEC 60870-5-103 protocol).

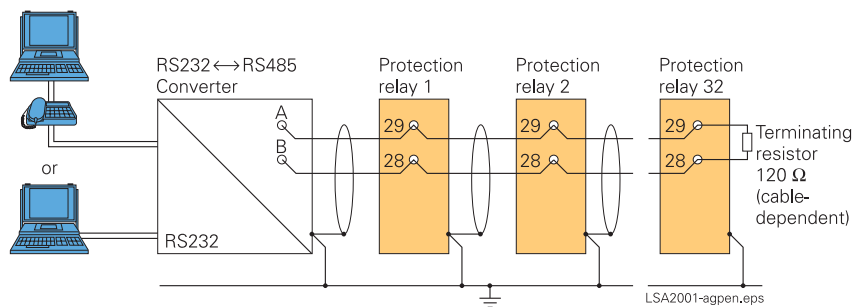
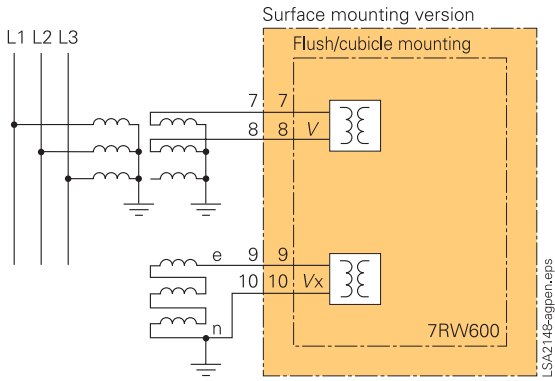
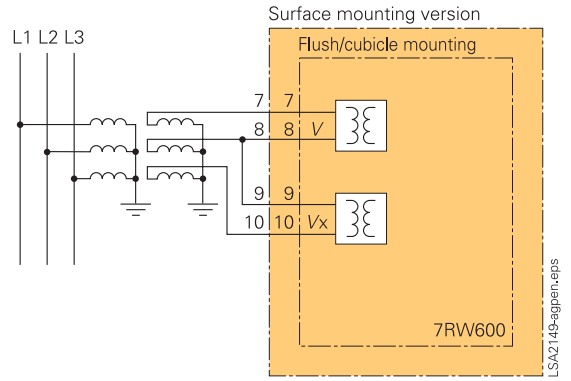

Fig. 11/80 Wiring communication

Connection diagrams



**Fig. 11/81**  
Connection of a phase-to-phase voltage  $V$  and a displacement voltage  $V_x$



**Fig. 11/82**  
Connection of two phase-to-phase voltages  $V$  to one voltage transformer set

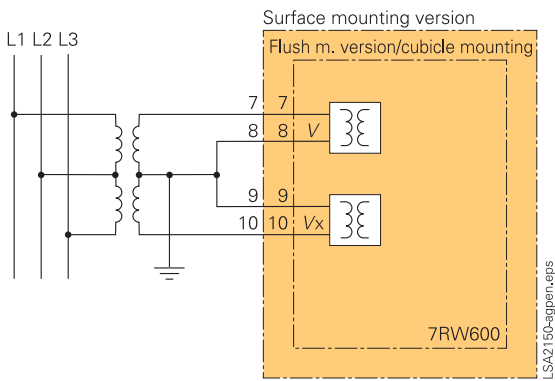

**Fig. 11/83**  
Connection to voltage transformers in V-configuration

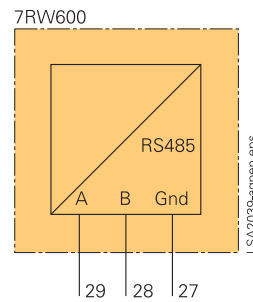

**Fig. 11/84**  
Communication port

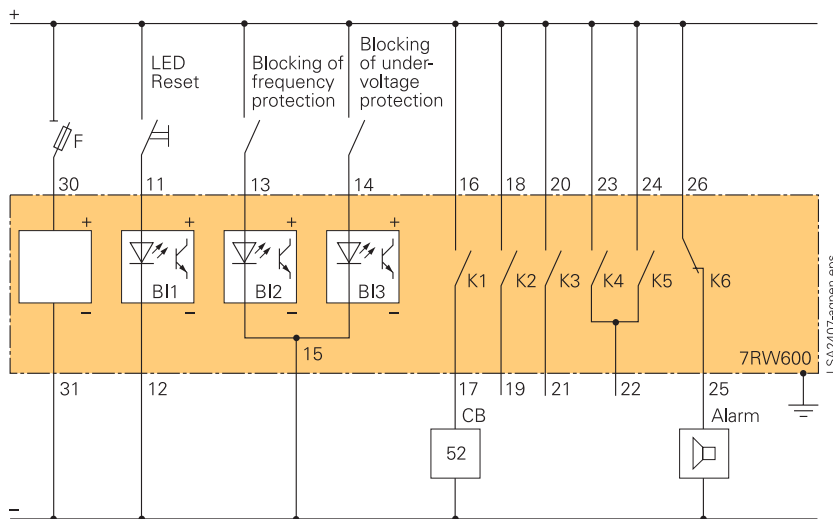

**Fig. 11/85**  
Typical auxiliary voltage wiring

## Technical data

<b>Hardware</b>	
<b>Measuring circuits (v.t. circuits)</b>	
Rated voltage $V_N$	100 to 125 V
Rated frequency $f_N$	50 or 60 Hz
Dynamic range	170 V
Power consumption	≤ 0.2 VA
Thermal overload capacity, continuous for ≤ 10 s	200 V 230 V
<b>Power supply via integrated DC/DC converter</b>	
Rated auxiliary voltage $V_{aux}$	24/48 V DC 60/110/125 V DC 220/250 V DC, 115 V AC
Maximum ripple at rated voltage	≤ 12 %
Power consumption	
Quiescent	Approx. 2 W
Energized	Approx. 4 W
Maximum bridging time following failure of auxiliary voltage	≥ 20 ms at $V_{AUX}$ (24 V DC) ≥ 50 ms at $V_{AUX}$ (110 V DC)
<b>Binary inputs</b>	
Number	3
Voltage range	24 to 250 V DC
Current consumption, independent of operating voltage	Approx. 2.5 mA
2 switching thresholds (adjustable)	17 V, 75 V
<b>Command contacts</b>	
Number of relays, total	6
Number of relays with 2-channel energization	2
Contacts per relay (K1 to K5)	1 NO contact
Contact for relay (K6)	1 NC contact or 1 NO contact (set via jumper)
Switching capacity	
Make	1000 W/VA
Break	30 W/VA
Switching voltage	250 V (AC/DC)
Permissible current, continuous	5 A
0.5 s	30 A
<b>LEDs</b>	
Ready-to-operate (green)	1
Marshalleable displays (red)	4
Fault indication (red)	1

<b>Serial port (isolated)</b>	
Type	RS485
Test voltage	2 kV AC for 1 min
Connections	Data cable at housing, two data wires, one frame reference for connection of a PC or similar
Transmission speed	At least 1200 baud, max. 19 200 baud
<b>Unit design</b>	
Case 7XP20	For dimensions, see dimension drawings, part 16
Weight	
Flush mounting/cubicle mounting	Approx. 4 kg
Surface mounting	Approx. 4.5 kg
Degree of protection to IEC 60529/EN 60529	IP 51

**Electrical test**

<b>Specifications</b>	
Standards	IEC 60255-5, ANSI / IEEE C37.90.0

**Insulation tests**

Voltage test (routine test)	
All circuits except auxiliary voltage and RS485	2.0 kV (rms), 50 Hz
Auxiliary voltage and RS485 only	2.8 kV DC
Voltage test (type test)	
Over open command contacts	1.5 kV (rms), 50 Hz
Impulse withstand capability (SWC) test (type test)	5 kV (peak); 1.2 / 50 μs; 0.5 J
All circuits, class III	3 positive and 3 negative impulses at intervals of 5 s
Test crosswise:	
Measurement circuits, pilot-wire connections, power supply, binary inputs, class III, (no tests crosswise over open contacts, RS485 interface terminals)	

**EMC tests, immunity; type tests**

Standards	IEC 60255-22 (product standard) EN 50082-2 (generic standard) DIN VDE 0435, Part 303
High-frequency test	2.5 kV (peak), 1 MHz, $\tau = 15 \mu\text{s}$ , 400 shots/s duration 2 s
IEC 60255-22-1, class III and DIN VDE 0435 Part 303, class III	
Electrostatic discharge	4 kV/6 kV contact discharge, 8 kV air discharge, both polarities, 150 pF, $R_t = 330 \Omega$
IEC 60255-22-2, class III and IEC 61000-4-2, class III	
Irradiation with RF field	
Non-modulated, IEC 60255-22-3 (report), class III	10 V/m, 27 to 500 MHz
Amplitude-modulated, IEC 61000-4-3, class III	10 V/m, 80 to 1000 MHz, 80 % AM, 1 kHz
Pulse-modulated, IEC 6100-4-3, class III	10 V/m, 900 MHz, repetition frequency 200 Hz, duty cycle 50 %

## Technical data

### EMC tests, immunity; type tests

Fast transients IEC 60255-22-4 and IEC 61000-4-4, class III	2 kV, 5/50 ns, 5 kHz, burst length 15 ms, repetition rate 300 ms, both polarities, $R_i = 50 \Omega$ , duration 1 min
Conducted disturbances induced by radio-frequency fields, amplitude-modulated, IEC 61000-4-6, class III	10 V, 150 kHz to 80 MHz, 80 % AM, 1 kHz
Power frequency magnetic field IEC 61000-4-8, class IV	30 A/m continuous, 50 Hz 300 A/m for 3 s, 50 Hz 0.5 mT; 50 Hz
Oscillatory surge withstand capability ANSI/IEEE C37.90.1 (common mode)	2.5 kV to 3 kV (peak), 1 MHz to 1.5 MHz, decaying oscillation, 50 shots per s, duration 2 s, $R_i = 150$ to $200 \Omega$
Fast transient surge withstand capability ANSI/IEEE C37.90.1 (common mode)	4 to 5 kV, 10/150 ns, 50 shots per s, both polarities, duration 2 s, $R_i = 80 \Omega$
Radiated electromagnetic interference ANSI/IEEE C37.90.2	10 to 20 V/m, 25 to 1000 MHz, amplitude- and pulse-modulated
High-frequency test Document 17C (SEC) 102	2.5 kV (peak, alternating polarity), 100, 1, 10 and 50 MHz, decaying oscillation, $R_i = 50 \Omega$

### EMC tests, emission; type tests

Standard	EN 50081-* (generic standard)
Conducted interference voltage, aux. voltage only CISPR 11, EN 55022, DIN VDE 0878 Part 22, limit value, class B	150 kHz to 30 MHz
Interference field strength CISPR 11, EN 55011, DIN VDE 0875 Part 11, limit value, class A	30 to 1000 MHz

### Mechanical stress tests

#### Vibration, shock stress and seismic vibration

##### During operation

Standards	IEC 60255-21 and IEC 60068-2
Vibration IEC 60255-21-1, class 2 IEC 60068-2-6	Sinusoidal 10 to 60 Hz: $\pm 0.035$ mm amplitude 60 to 150 Hz: 0.5 g acceleration Sweep rate 1 octave/min 20 cycles in 3 orthogonal axes
Shock IEC 60255-21-2, class 1 IEC 60068-2-27	Half-sinusoidal acceleration 5 g, duration 11 ms 3 shocks in each direction of 3 orthogonal axes
Seismic vibration IEC 60255-21-3, class 1  IEC 60068-2-59	Sinusoidal 1 to 8 Hz: $\pm 4$ mm amplitude (horizontal axis) 1 to 8 Hz: $\pm 2$ mm amplitude (vertical axis) 8 to 35 Hz: 1 g acceleration (horizontal axis) 8 to 35 Hz: 0.5 g acceleration (vertical axis) Sweep rate 1 octave/min 1 cycle in 3 orthogonal axes

##### During transport

Standards	IEC 60255-21 and IEC 60068-2
Vibration IEC 60255-21-1, class 2 IEC 60068-2-6	Sinusoidal 5 to 8 Hz: $\pm 7.5$ mm amplitude; 8 to 150 Hz: 2 g acceleration Sweep rate 1 octave/min 20 cycles in 3 orthogonal axes
Shock IEC 60255-21-2, class 1 IEC 60068-2-27	Half-sinusoidal acceleration 15 g, duration 11 ms, 3 shocks in each direction of 3 orthogonal axes
Continuous shock IEC 60255-21-2, class 1 IEC 60068-2-29	Half-sinusoidal acceleration 10 g, duration 16 ms, 1000 shocks in each direction of 3 orthogonal axes

### Climatic stress tests

#### Temperatures

Recommended temperature during service	-5 to +55 °C (legibility may be impaired > +55 °C)
----------------------------------------	-------------------------------------------------------

#### Temperature tolerances:

During service	-20 to +70 °C
During storage	-25 to +55 °C
During transport (storage and transport in standard works packaging)	-25 to +70 °C

#### Humidity

Permissible humidity stress It is recommended to arrange the units in such a way that they are not exposed to direct sunlight or pronounced temperature changes that could cause condensation	Annual average $\leq 75$ % relative humidity, on 30 days during the year 95 % relative humidity, condensation not permitted!
--------------------------------------------------------------------------------------------------------------------------------------------------------------------------------------------------	------------------------------------------------------------------------------------------------------------------------------

### Functions

#### Undervoltage protection

Setting range $V <$ , $V_x < V_p <$	20 to 120 V (in steps of 1 V)
Delay times	0 to 60 s (in steps of 0.01 s) or $\infty$ (i.e. non-effective)
Time multiplier for inverse characteristic	0.1 to 5 s
Pickup time	$\leq 50$ ms
Reset time	$\leq 50$ ms
Reset ratio	1.05
Tolerances	
Voltage pickup	3 % of setting value or 1 V
Delay times	1 % of setting value or 10 ms

#### Overvoltage protection

Setting range $V >$ , $V >>$ $V_x >$ , $V_x >>$	20 to 170 V (in steps of 1 V) 10 to 170 V (in steps of 1 V)
Delay times	0 to 60 s or $\infty$ (in steps of 0.01 s)
Pickup time	$\leq 50$ ms
Reset time	$\leq 50$ ms
Reset ratio	0.95
Tolerances	
Voltage pickup	3 % of setting value or 1 V < 1 % of setting value for $V > V_n$
Delay times	1 % of setting value or 10 ms

### Technical data

#### Frequency protection

Number of frequency stages $f >$ or $f <$	4
Setting range $f >$ or $f <$	40 to 68 Hz (in steps of 0.01 Hz)
Delay times	0 to 60 s or $\infty$ (in steps of 0.01 s)
Undervoltage blocking	20 to 100 V or $\infty$ (in steps of 1 V)
Pickup time $f >$ , $f <$	Approx. 100 ms
Reset times $f >$ , $f <$	Approx. 100 ms
Reset difference	Approx. 20 mHz
Reset ratio (undervoltage blocking)	1.05
Tolerances	
Frequencies $f >$ , $f <$	5 mHz at $f = f_N$ and $V = V_N$ 10 mHz at $f = f_N$
Undervoltage blocking	3 % of setting value or 1 V
Delay times	1 % of setting value or 10 ms

#### Rate-of-frequency-change protection

Number of rates-of-frequency-changing stages	4
Setting range $\frac{df}{dt}$	0.4 to 10 Hz/s or $\infty$ (in steps of 0.1 Hz/s)
Delay times	0 to 60 s or $\infty$ (in steps of 0.01 s)
Undervoltage blocking	20 to 100 V or $\infty$ (in steps of 1 V)
Pickup time $\frac{df}{dt}$	Approx. 200 ms
Reset ratio pickup $\frac{df}{dt}$	Approx. 0.6
Reset ratio (undervoltage blocking)	1.05
Tolerances	
Changes of frequencies $\frac{df}{dt}$	
In the 45 to 50 Hz range	100 mHz/s at $f_N = 50$ Hz and $V = V_N$
In the 54 to 60 Hz range	150 mHz/s at $f_N = 60$ Hz and $V = V_N$
Undervoltage blocking $V <$	3 % of setting value or 1 V
Delay times	1 % of setting value or 10 ms

#### Overexcitation protection

Warning stage $\frac{V/V_N}{f/f_N}$	1 to 1.2 (in steps of 0.01)
Tripping stage $\frac{V/V_N}{f/f_N}$	1 to 1.4 (in steps of 0.01)
Delay times, warning and tripping stages	0 to 60 s, or $\infty$ (in steps of 0.01 s)
Curve values $V/f$	1.1 / 1.15 / 1.2 / 1.25 / 1.3 / 1.35 / 1.4
Associated delay times	0 to 20000 s (in steps of 1 s)
Cooling-down time	0 to 20000 s (in steps of 1 s)
Voltage transformer adaption factor	0.5 to 2 (in steps 0.01)
Pickup response time (stage curve)	$\leq 50$ ms
Reset time (stage curve)	$\leq 60$ ms
Reset ratio	0.95
Tolerances	
Overexcitation $V/f$	3 % of setting value
Delay times (stage curve)	1 % of setting value or 10 ms
Delay times (dependent curve)	5 % with respect to $V/f$ value $\pm 0.5$ s

#### Fault recording

Instantaneous value fault record	
Measured values	$V, V_x$
Pattern	1.00 ms (50 Hz) 0.83 ms (60 Hz)
Fault record duration	Max. 5 s
Start signal	Tripping, energization, binary input, PC
R.m.s. fault record	
Measured values	$V, V_x, f, f_N$
Pattern	10 ms (50 Hz) 8.3 ms (60 Hz)
Fault record duration	Max. 50 s
Starting signal	Tripping, energization, binary input, PC

#### Operational measured values

Measured values	$V, V_x, V_i, V/f, f$
Measuring range voltage	0 to 170 V
Tolerance	$\leq 2$ V or 5 %
Measuring range overexcitation	0 to 2.4
Tolerance	$\leq 5$ %
Measuring range frequency	25 to 70 Hz
Tolerance	$\leq 0.05$ Hz or 5 MHz at $f = f_N$

#### CE conformity

This product is in conformity with the Directives of the European Communities on the harmonization of the laws of the Member States relating to electromagnetic compatibility (EMC Council Directive 89/336/EEC) and electrical equipment designed for use within certain voltage limits (Council Directive 73/23/EEC).

This unit conforms to the international standard IEC 60255, and the German standard DIN 57435/Part 303 (corresponding to VDE 0435/Part 303). The unit has been developed and manufactured for application in an industrial environment according to the EMC standards.

This conformity is the result of a test that was performed by Siemens AG in accordance with Article 10 of the Council Directive complying with the generic standards EN 50081-2 and EN 50082-2 for the EMC Directive and standard EN 60255-6 for the "low-voltage Directive".

## Selection and ordering data

Description	Order No.
<b>7RW600 numerical voltage, frequency and overexcitation protection relay</b>	<b>7RW6000-□□A□0-□□A0</b>
<b>Rated auxiliary voltage</b>	
24, 48 V DC	2
60, 110, 125 V DC	4
220, 250 V DC, 115 V AC	5
<b>Unit design</b>	
For panel surface mounting, terminals on the side	B
For panel flush mounting/cubicle mounting, terminals on the rear	E
<b>Languages</b>	
English	0
German	1
Spanish	2
French	3
<b>Scope of functions</b>	
Voltage and frequency protection	0
Voltage, frequency and rate-of-frequency-change protection	1
Voltage and overexcitation protection	2
<b>Serial system interface</b>	
With RS485 port	D

## Accessories

<b>DIGSI 4</b>	
Software for configuration and operation of Siemens protection units running under MS Windows (version Windows 95 and higher) device templates, Comtrade Viewer, electronic manual included as well as "Getting started" manual on paper, connecting cables (copper)	
Basis	
Full version with license for 10 computers, on CD-ROM (authorization by serial number)	7XS5400-0AA00
Demo	
Demo version on CD-ROM	7XS5401-0AA00
Professional	
Complete version: DIGSI 4 Basis and additionally SIGRA (fault record analysis), CFC Editor (logic editor), Display Editor (editor for default and control displays) and DIGSI 4 Remote (remote operation)	7XS5402-0AA00
<b>SIGRA</b>	
(generally contained in DIGSI Professional, but can be ordered additionally) Software for graphic visualization, analysis and evaluation of fault records. Can also be used for fault records of devices of other manufacturers (Comtrade format). Running under MS Windows 95/98/ME/NT/2000/XP Professional. Incl. templates, electronic manual with license for 10 PCs. Authorization by serial number. On CD-ROM.	7XS5410-0AA00
<b>Converter V.24 - RS485*</b>	
With communication cable for the SIPROTEC 7RW600 numerical voltage, frequency and overexcitation relay; length 1 m	
With plug-in power supply unit 230 V AC	7XV5700-0□□00 <sup>1)</sup>
With plug-in power supply unit 110 V AC	7XV5700-1□□00 <sup>1)</sup>
<b>Converter, full-duplex FO cable, RS485, with built-in power supply unit</b>	
Auxiliary voltage 24 - 250 V DC and 110 / 230 V AC	7XV5650-0BA00
<b>Manual for 7RW600</b>	
English	C53000-G1176-C117-4

1) Possible versions see part 14, page 14/61

\* RS485 bus system up to 115 kbaud  
RS485 cable and adaptor  
7XV5103-□AA□□see part 14,  
page 14/5

Connection diagrams

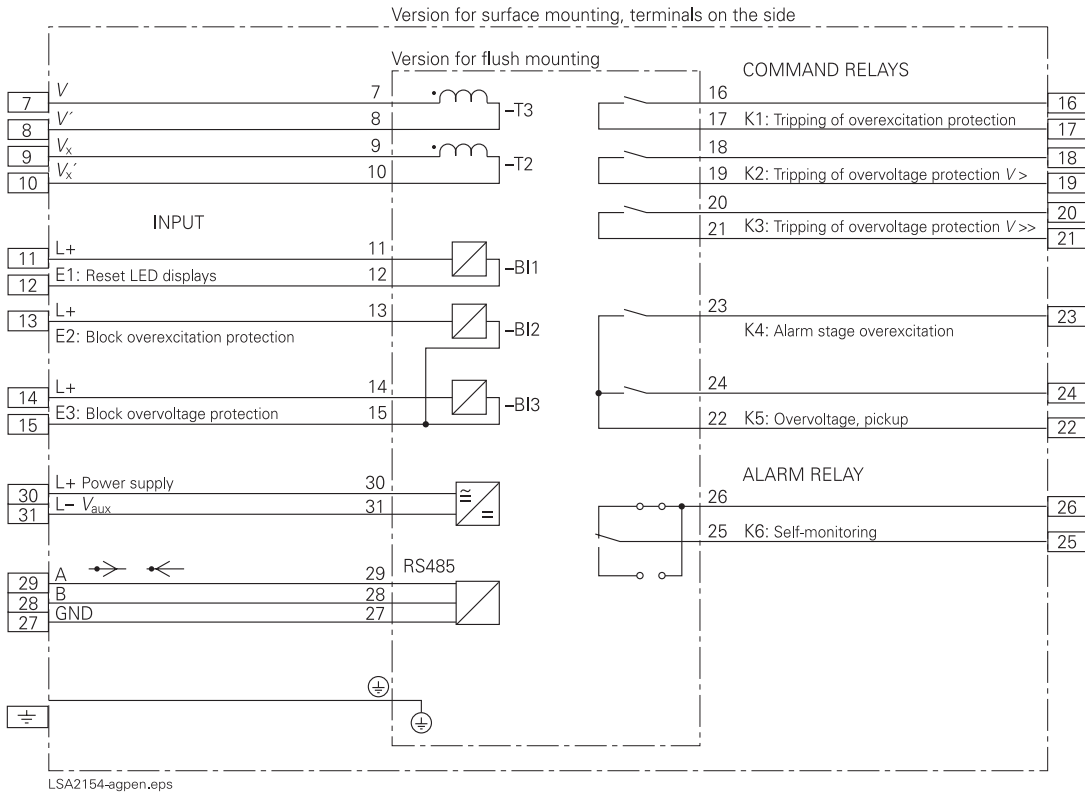

**Fig. 11/86**  
Connection circuit diagram of 7RW600 voltage and frequency protection with pre-setting of marshallable binary inputs and command contacts. (Ordering Code: 7RW600x-xBxxx-; 7RW600x-xExxx-).

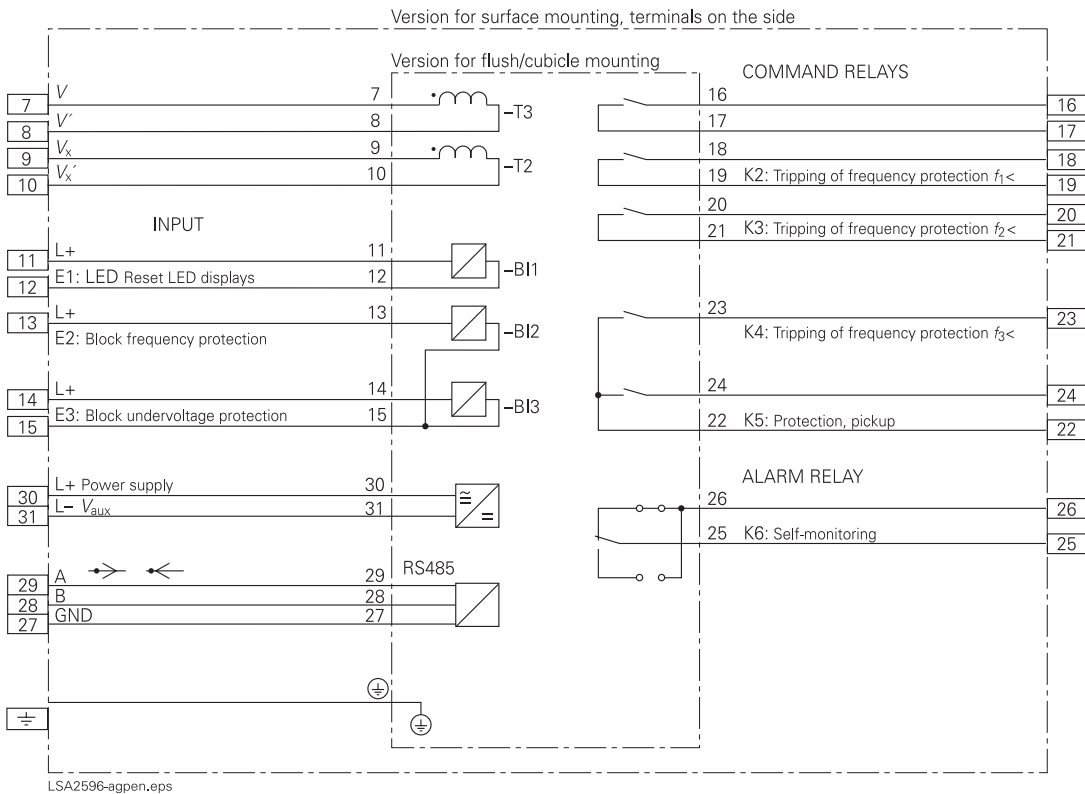

**Fig. 11/87**  
Connection circuit diagram of 7RW600 voltage and overexcitation protection with pre-setting of marshallable binary inputs and command contacts. (Ordering Code: 7RW600x-xBxxx-; 7RW600x-xExxx-).

Dimension drawings in mm / inch

Dimension drawings for 1/6 x 19" housing (7XP20)

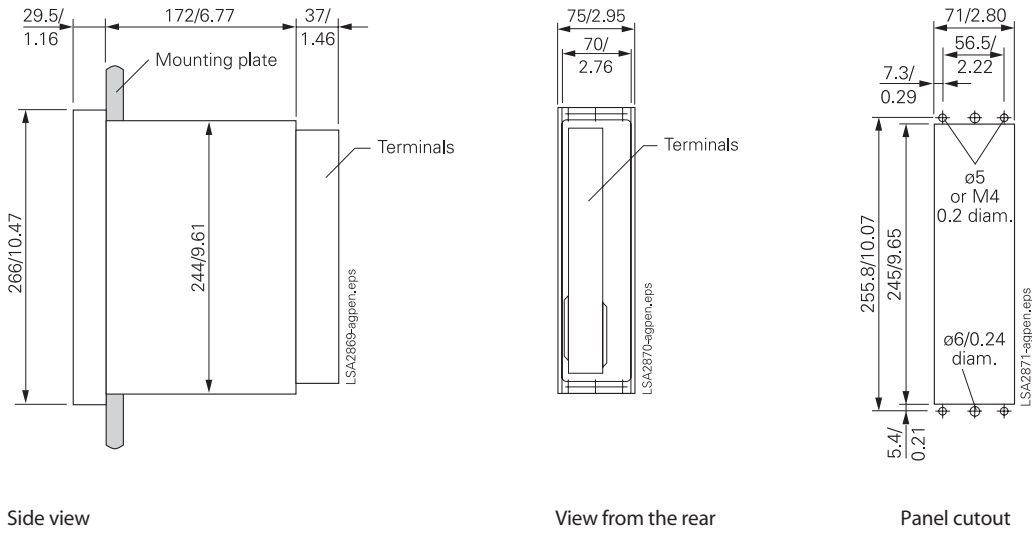

Side view

View from the rear

Panel cutout

**Fig. 16/15**  
Housing for panel flush mounting/  
cubicle mounting, terminals at rear (1/6 x 19")

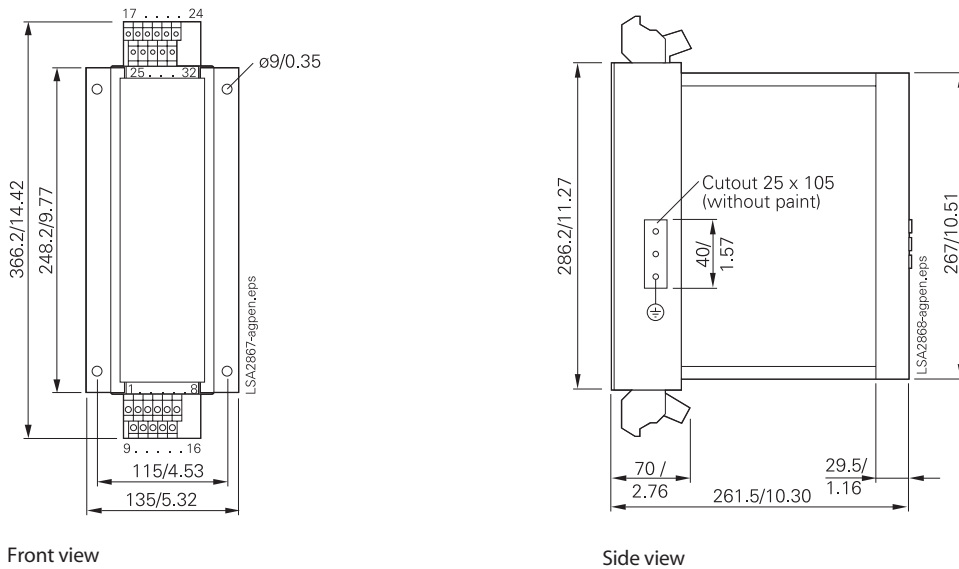

Front view

Side view

**Fig. 16/16**  
Housing for surface mounting,  
terminals at top and bottom (1/6 x 19")

Dimension drawings in mm / inch

Dimension drawings for 1/6 x 19" housing (7XP20)

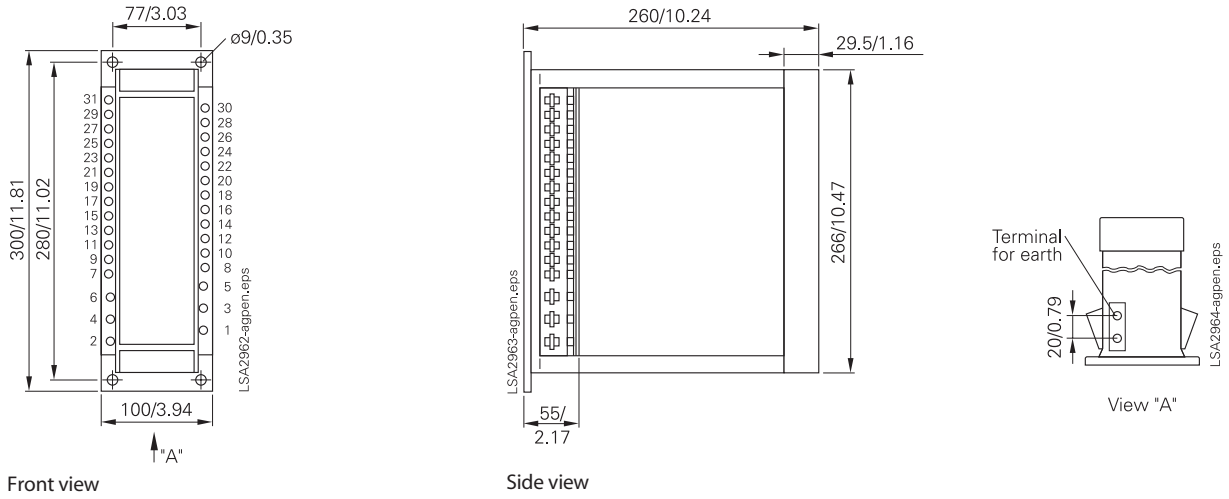

**Fig. 16/17**  
Housing for panel surface mounting, terminals on the side (1/6 x 19")



SIEMENS WEB-SITE : □

PTD : [www.siemens.com/ptd](http://www.siemens.com/ptd) □

Relay : [http://siemens.siprotec.de/download\\_neu/index\\_e.htm](http://siemens.siprotec.de/download_neu/index_e.htm) □

Power Quality : [http://www.powerquality.de/pq\\_da/index\\_e.htm](http://www.powerquality.de/pq_da/index_e.htm) □

IEC 61850 : [www.61850.com](http://www.61850.com) □

SIEMESN TAIWAN : [www.siemens.com.tw](http://www.siemens.com.tw) □